



US 20040122461A1

(19) **United States**

(12) **Patent Application Publication**
McGuire et al.

(10) **Pub. No.: US 2004/0122461 A1**

(43) **Pub. Date: Jun. 24, 2004**

(54) **SURGICAL BITING PUNCH**

Publication Classification

(76) Inventors: **David A. McGuire**, Anchorage, AK
(US); **Paul A. Torrie**, Marblehead, MA
(US)

(51) **Int. Cl.⁷ A61B 17/32**

(52) **U.S. Cl. 606/184**

(57) **ABSTRACT**

Correspondence Address:
JOEL PETROW
Smith & Nephew, Inc.
1450 Brooks Road
Memphis, TN 38116 (US)

A surgical punch including an upper jaw and lower jaw that are coupled at their proximal ends. The jaws have cutting edges at their distal end configured to cut in a direction from the distal ends of the jaws towards the proximal ends of the jaws. The center of rotation of the cutting trajectory can be located above the initial cutting point of the lower jaw. The upper jaw can include a reversed slope leading edge. The jaws can be slidably coupled to each other. The coupling member can include a pin and slot to couple the movable jaw to an actuating rod.

(21) Appl. No.: **10/323,578**

(22) Filed: **Dec. 18, 2002**

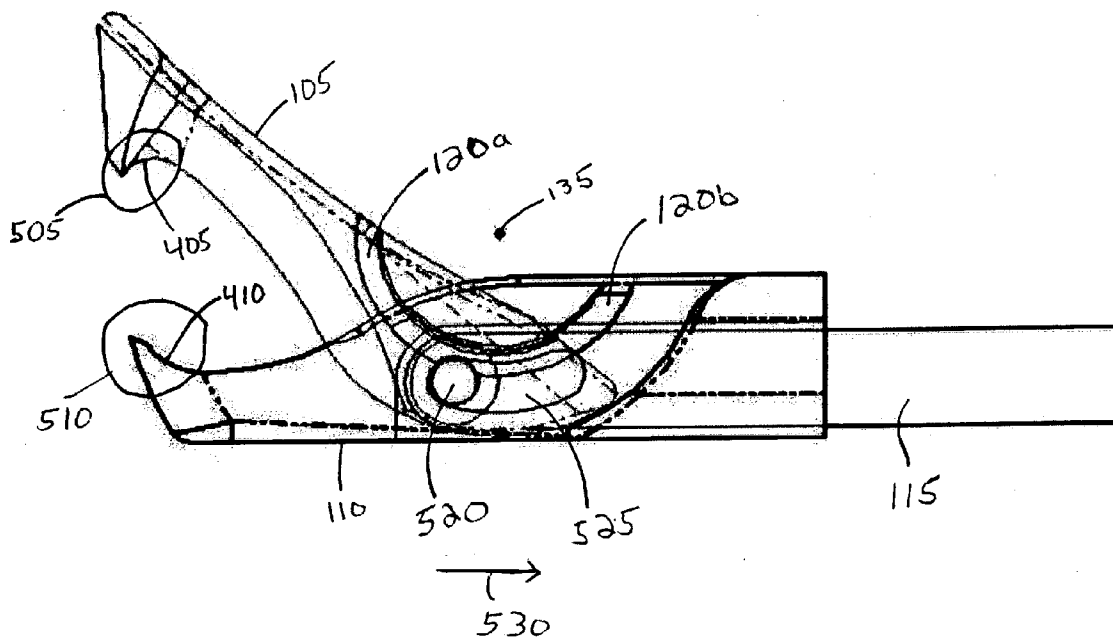

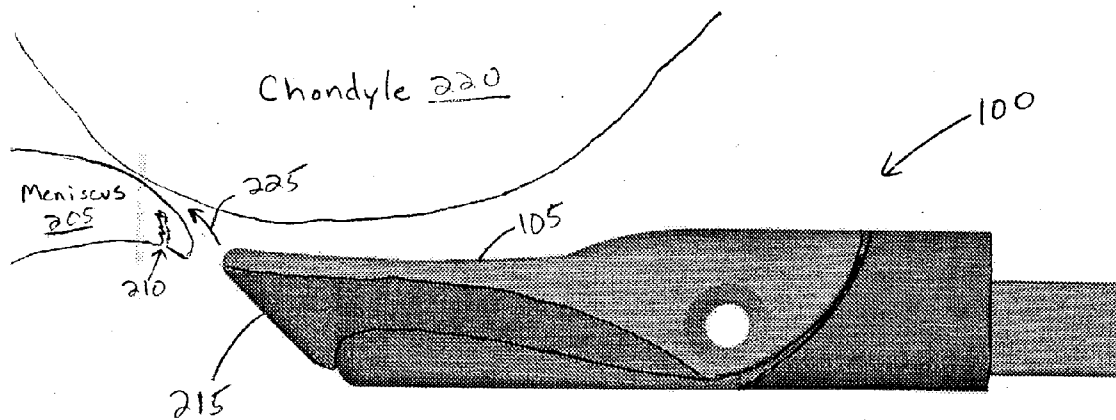
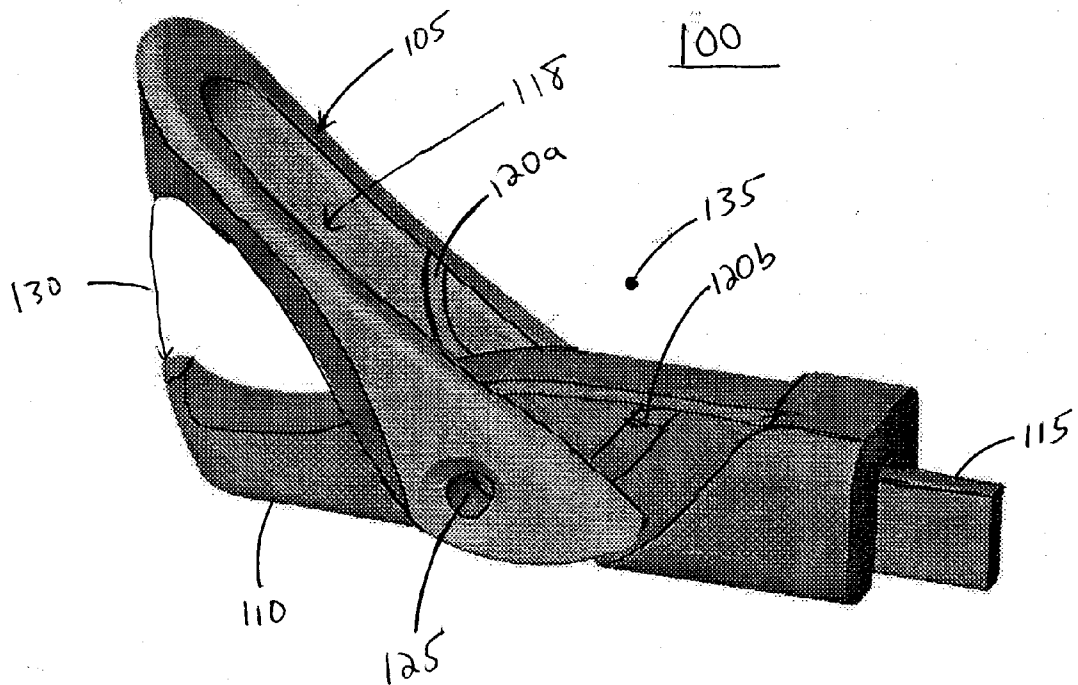

FIG. 1



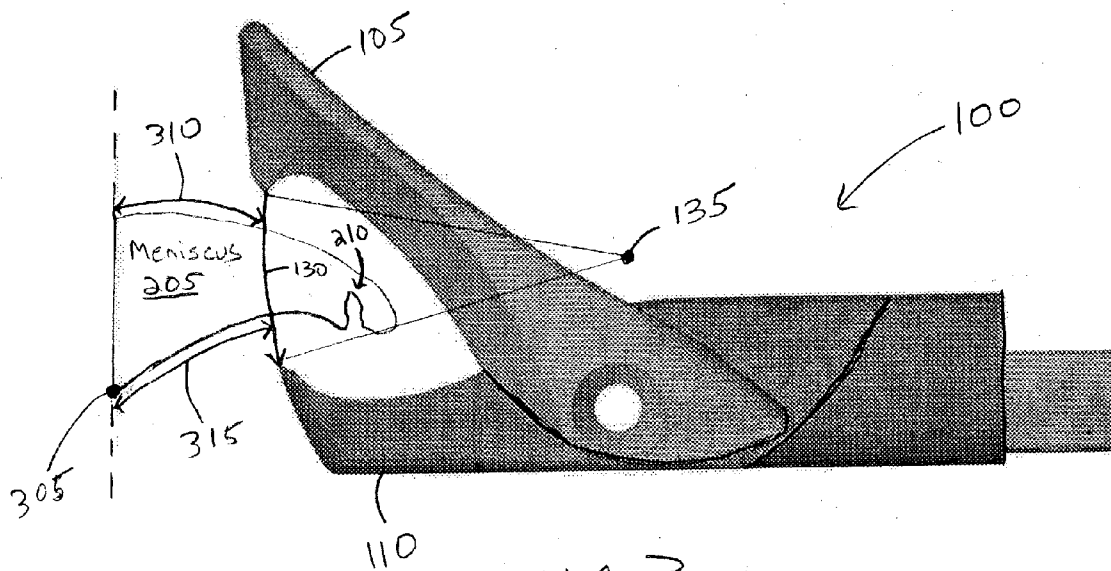

FIG. 3

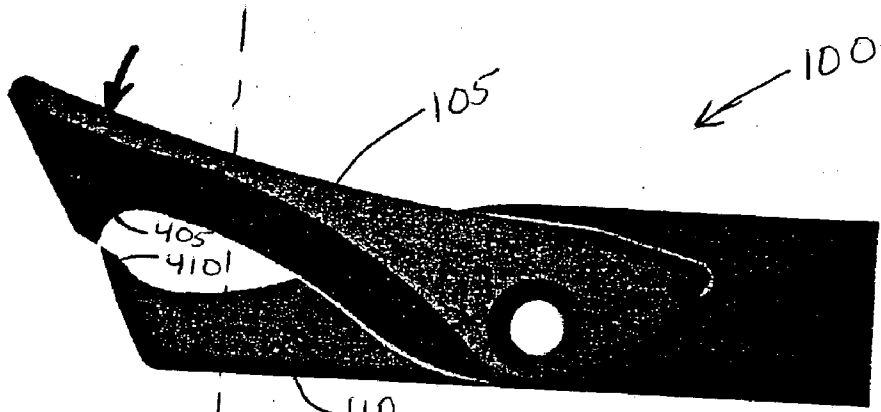

FIG. 4A

420

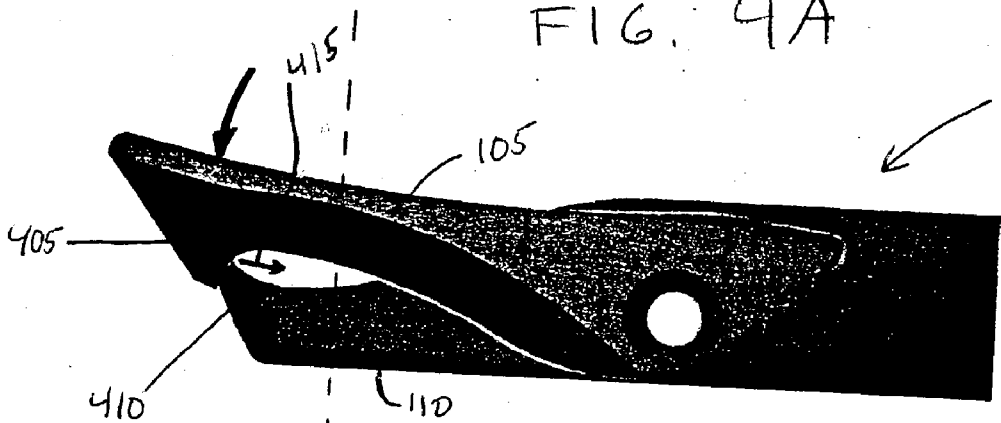

FIG. 4B

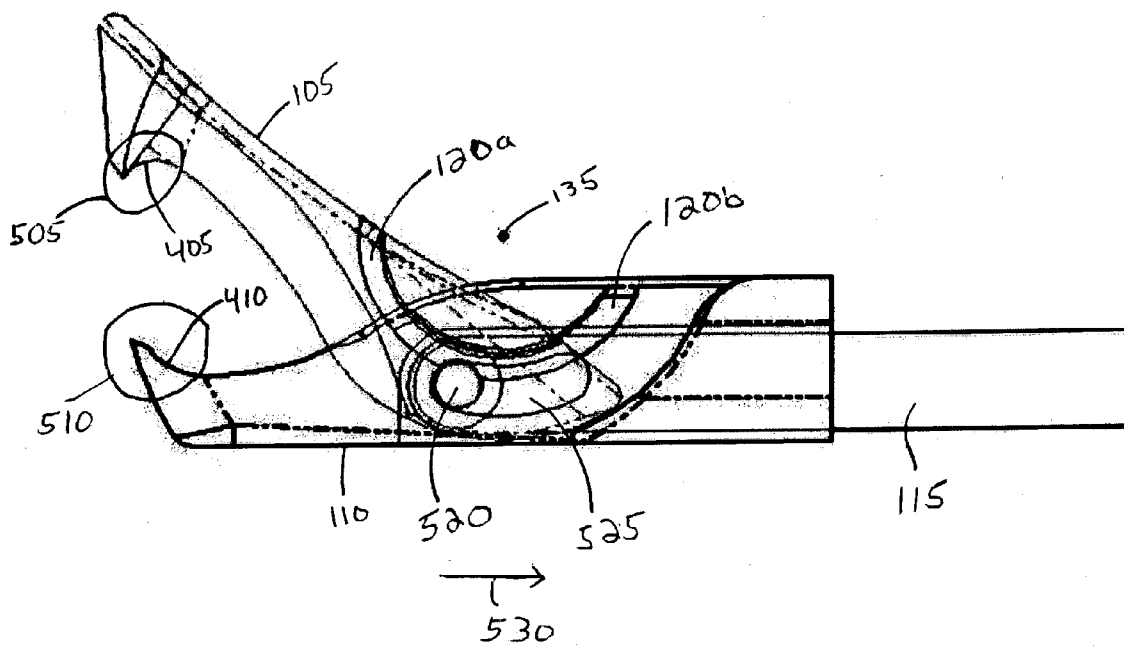

FIG. 5

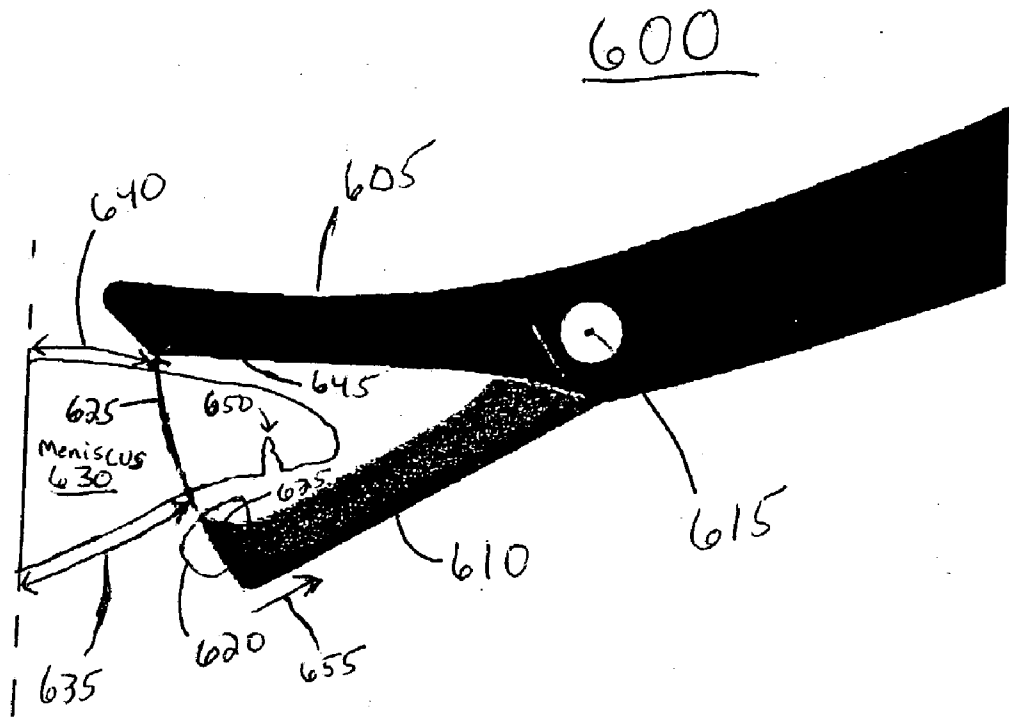

FIG. 6

SURGICAL BITING PUNCH

TECHNICAL FIELD

[0001] This invention relates to medical devices, and more particularly to a surgical biting punch.

BACKGROUND

[0002] The meniscus is a C-shaped piece of fibro cartilage that is located at the peripheral aspect of the knee joint, between the femur and the tibia. There are two menisci in each knee, the medial meniscus, and the lateral meniscus. The two menisci absorb shock and spread the force of weight bearing on the joint over a larger area. They also stabilize the ligaments of the knee. The majority of the meniscus has little or no blood supply. For that reason, when damaged, the meniscus does not heal as quickly as other tissue. In addition, the meniscus begins to deteriorate over time, often developing degenerative tears.

[0003] Typically, when the meniscus is damaged, the torn piece begins to move abnormally within the joint. Because the space between the bones of the joint is very small, as the abnormally mobile piece of meniscal tissue moves, it may become caught between the femur and tibia. Usually this situation requires that the torn piece be removed. A surgeon can use an instrument, often referred to as a "biter" to remove the tear. The instrument is referred to as a biter because its cutting edges are typically in the shape of a semi-circle or a square and part of jaws that open and close. The cutting edges therefore cut a piece of the meniscus in the shape of a semi-circle or a square when the jaws are closed, giving the appearance of taking a bite.

SUMMARY

[0004] In one aspect there is a surgical punch including a first jaw having a first cutting edge, a second jaw having a second cutting edge and a coupling member. The coupling member is disposed at proximal end portions of the first and second cutting edges and configured to bring the first and second jaws towards each other when actuated. Further, the jaws are configured to cause cutting from distal ends towards proximal ends of the jaws when the jaws are brought towards each other.

[0005] In other examples, the surgical punch can include one or more of the following features. A portion of the first cutting edge can be disposed distal to the second cutting edge. The first cutting edge can further include a first distal portion that is closest to the second jaw at a distal end of the first distal portion and farthest from the second jaw at a proximal end of the first distal portion when the first jaw is parallel to the second jaw. The second cutting edge can further include a second distal portion that is closest to the first jaw at a distal end of the second distal portion and farthest from the first jaw at a proximal end of the second distal portion when the first jaw is parallel to the second jaw.

[0006] The surgical punch can also include a projected point of rotation of the cutting located outside of the coupling member. The first jaw can be an upper jaw and the second jaw can be a lower jaw, and the surgical punch can further include a projected point of rotation of the cutting that is located above an initial cutting point of the second cutting edge. The first jaw can further include a leading edge

having a reverse slope. The leading edge can be configured to guide the first jaw between a meniscus and a femoral condyle associated with the meniscus.

[0007] The coupling member can include a pivot pin. The coupling member can include a pinless hinge, wherein the first jaw is slidably coupled to the second jaw. The coupling member can include one of an arcuate flange and an arcuate groove.

[0008] The surgical punch can be configured where the coupling member further comprises the following:

[0009] one of the jaws comprising at least one first arcuate flange and the other of the jaws comprising at least one first arcuate groove, the at least one first arcuate flange being slidably disposed in the at least one first arcuate groove so as to pivotally couple the first jaw to the second jaw, whereby the first jaw is capable of pivotal movement towards and away from the second jaw, with the at least one first arcuate flange and the at least one first arcuate groove having a first center of curvature that is fixed in position relative to the second jaw when the at least one first arcuate flange is disposed in the at least one first arcuate groove, and

[0010] one of the first jaw and an actuating member comprising at least one second arcuate flange and the other of the first jaw and the actuating member comprising at least one second arcuate groove, the at least one second arcuate flange being slidably disposed in the at least one second arcuate groove so as to pivotally couple the actuating member to the first jaw, with the at least one second arcuate flange and the at least one second arcuate groove having a second center of curvature that is fixed in position relative to the actuating member and is not fixed in position relative to the second jaw when the at least one second arcuate flange is disposed in the at least one second arcuate groove, and one of the centers of curvature is displaced laterally from the second stationary jaw and the actuating member,

[0011] whereby (a) when the actuating member is actuated in a first direction relative to the second jaw, the first jaw will open away from the second jaw, and (b) when the actuating member is moved in a second opposite direction relative to the second jaw, the first jaw will close towards the second jaw, the first and second jaws being arranged so that body tissue located between the first and second jaws may be severed in a punching motion as the jaws are opened and closed relative to one another by actuating the actuating member.

[0012] The coupling member can also include a pin coupled to the first jaw and an actuating member and a slot to receive the pin, where the slot is configured to allow free passage of the pin as the actuating member is actuated. The slot can include an arcuate portion. The first jaw can be a movable jaw and the second jaw can be a stationary jaw. The first jaw can be a stationary jaw and the second jaw can be a movable jaw.

[0013] In another aspect, there is a surgical punch that includes a first movable jaw, a second stationary jaw and a coupling member. The first movable jaw has a first cutting

edge and a leading edge including a reverse slope. The second stationary jaw has a second cutting edge disposed proximal to a portion of the first cutting edge. The coupling member slidably couples the first jaw to the second jaw. The coupling member is disposed at proximal end portions of the first and second cutting edges, and configured to bring the first and second jaws towards each other when actuated. The jaws are configured to cause cutting from distal ends towards proximal ends of the jaws when the jaws are brought towards each other.

[0014] In another aspect, there is a surgical punch including an actuating rod, a first jaw, a second jaw, a pin, and a coupling member. The first jaw has a first cutting edge. The pin movably couples the first jaw to the actuating rod. The second jaw has a second cutting edge and a slot configured to allow free passage of the pin as the actuating member is actuated. The coupling member is disposed at proximal end portions of the first and second cutting edges. The coupling member includes a flange and a groove configured to bring the first and second jaws towards each other when actuated.

[0015] In another aspect, there is a surgical punch including a first jaw, a second jaw and a coupling member. The upper jaw has a first cutting edge. The lower jaw has a second cutting edge. The coupling member couples the upper jaw to the lower jaw. The coupling member includes a center of rotation, where the center of rotation is configured to cause a predefined vertical cut in target tissue. In one example, the predefined cut is more distal, with respect to the surgical punch, at an end of the tissue closest to the upper jaw than at an end of the tissue closest to the lower jaw. The surgical punch can also include one or more of the features listed above.

[0016] The details of one or more embodiments of the invention are set forth in the accompanying drawings and the description below. Other features, objects, and advantages of the invention will be apparent from the description and drawings, and from the claims.

DESCRIPTION OF DRAWINGS

[0017] FIG. 1 is a side view of a surgical punch with closed jaws.

[0018] FIG. 2 is a perspective view of the surgical punch.

[0019] FIG. 3 is a side view of the surgical punch with open jaws.

[0020] FIGS. 4A and 4B are side views of the surgical punch with jaws closing.

[0021] FIG. 5 is a transparent side view of the surgical punch.

[0022] FIG. 6 is a side view of another example of a surgical punch.

[0023] Like reference symbols in the various drawings indicate like elements.

DETAILED DESCRIPTION

[0024] FIG. 1 illustrates a surgical punch 100 for use in repairing a meniscus 205 having a tear 210. Surgical punch 100 includes a moveable upper jaw 105 having a sloped leading edge 215 with a reverse slope. In other words, the slope of leading edge 215 from the distal end to the proximal

end is negative. This reverse sloped leading edge 215 enables a surgeon to guide the distal end of surgical punch 100 between meniscus 205 and a femoral condyle 220, as indicated by arrow 225. Leading edge 215 also enables a surgeon to easily position upper jaw 105 above meniscus 205 for a cutting procedure.

[0025] Referring to FIG. 2 surgical punch 100 also includes a stationary lower jaw 110 and an actuating rod 115. Actuating rod 115 is connected to handles (not shown), such as scissor-like handles typically seen on biting punches and other similar surgical instruments. The handles move actuating rod 115 towards and away from moveable jaw 105 and stationary jaw 110. During use, when actuating rod 115 is moved away from the distal end of the punch, jaws 105 and 110 move toward each other (i.e., close). As a surgeon moves actuating rod 115 away from jaws 105 and 110, upper jaw 105 moves away from lower jaw 110 (i.e., open). When viewed from above, upper jaw 105 is "U" shaped and has an opening 118. This opening 118 allows a surgeon to view the portion of the target tissue that will be cut by surgical punch 100.

[0026] To enable upper jaw 105 to move, surgical punch 100 includes a sliding coupling mechanism 120. Sliding mechanism 120 has a groove 120a, in the shape of a semi-circle, located on the inner walls of upper jaw 105. Sliding mechanism 120 also has a corresponding flange 120b, also in the shape of a semi-circle, located on the outer walls of lower jaw 110. As upper jaw 105 moves, groove 120a slides along and is guided by flange 120b. To connect upper jaw 105 to actuating rod 115, feature 125 includes a pin 520 (FIG. 5). The pin 520 extends from one side of upper jaw 105, through actuating rod 115, to the other side of upper jaw 105. To accommodate this pin 520, lower jaw 110 includes a slot 525 (FIG. 5) so that there is no obstructing material as the pin 520 moves with upper jaw 105 as actuating rod 115 moves.

[0027] The pin 520 at feature 125 is not a pivot pin about which upper jaw 105 rotates. Unlike the alternative example described below, sliding mechanism 120 does not include a pivot pin. Because upper jaw 105 slides, the cutting trajectory 130 has a projected center of rotation 135 that is outside of and above the jaws 105 and 110. As described in more detail below, having a projected center of rotation 135 above the initial cutting point of lower jaw 110 allows cutting by upper jaw 105, along trajectory 130, to be more distal when jaws 105 and 110 are furthest apart (as shown) than when jaws 105 and 110 are closed.

[0028] FIG. 3 illustrates jaws 105 and 110 in an open position around meniscus 205, ready to begin a cutting procedure. Meniscus 205 attaches at point 305 to the tibial plateau. The meniscus 205 can also attach along the vertical rear edge (from point 305 and up). Arrow 310 represents the distance along the top of meniscus 205 from the plane of attachment to the cut, at the cutting trajectory 130, made by surgical punch 100. Similarly, arrow 315 represents the distance along the bottom of meniscus 205 from the plane of attachment to the cut, at the cutting trajectory 130, made by surgical punch 100. The larger the difference between distance 315 and distance 310, the more stable the remaining meniscus will be. As described above, the projected center of rotation 135 for cutting trajectory 130 is above lower jaw 110 for surgical punch 100. This means that the cutting

trajectory **130** is more distal at the top of meniscus **205** than at the bottom of meniscus **205**. The higher the projected center of rotation **135** is above the lower jaw **110**, the more distal the cutting trajectory **130** will be at the top of meniscus **205**, as compared with the bottom of meniscus **205**. In other words, the higher the projected center of rotation **135** is, the greater the difference between distances **310** and **315**.

[0029] FIGS. 4A and 4B illustrate how surgical punch **100** cuts tissue during a cutting procedure, from the punch's distal end towards its proximal end. Referring to FIG. 4A, as jaws **105** and **110** move towards each other, cutting edge **405** of upper jaw **105** meets cutting edge **410** of lower jaw **110**. When cutting edges **405** and **410** first meet, they meet at the distal end of punch **100**, at the most distal point of lower jaw **110**. Because cutting edges **405** and **410** are configured into sharp, pointed edges at the first point of contact with the tissue, cutting edges **405** and **410** initially pierce the meniscus **205** (FIG. 3) at a location that is distal, with respect to punch **100**, to tear **210** (FIG. 3).

[0030] Referring to FIG. 4B, as jaws **105** and **110** continue to close, the distal ends of cutting edges **405** and **410** start to overlap each other. As cutting edges **405** and **410** overlap, the overlap at the distal ends of jaws **105** and **110** starts at the distal most point of cutting edges **405** and **410** and moves proximally, as indicated by arrow **415**. This also means that cutting edges **405** and **410** cut tissue in a direction from the distal end of punch **100** toward the proximal end, as indicated by arrow **415**. It may be worth noting that the proximal ends of jaws **105** and **110** also overlap. As jaws **105** and **110** close, the overlap at the proximal ends of jaws **105** and **110** occurs in a direction from the proximal end towards the distal end, the opposite direction of arrow **415**. Arbitrarily placed dashed line **420** helps illustrate this. The portions of jaws **105** and **110** that are distal to dashed line **420** have cutting edges **405** and **410** that overlap each other in a direction that is distal to proximal, as indicated by arrow **415**. The portions of jaws **105** and **110** that are proximal to dashed line **420** overlap each other in a direction that is proximal to distal, the opposite of arrow **415**.

[0031] FIG. 5 illustrates the geometry of a distal portion **505** of cutting edge **405** and a distal portion **510** of cutting edge **410**. Distal portion **505** has a sharp, positive, and changing slope. The positive slope on upper jaw **105** ensures that as jaws **105** and **110** close, the overlap of cutting edges **405** and **410** progresses in a direction that is distal to proximal, with respect to jaws **105** and **110**. Distal portion **510** has a sharp, negative, and changing slope. Similarly, the negative slope on lower jaw **110** ensures that as jaws **105** and **110** close, the overlap of cutting edges **405** and **410** progresses in a direction that is distal to proximal, with respect to jaws **105** and **110**. To maintain the progression of the overlap in a direction that is distal to proximal, the slopes can be configured based on projected center of rotation **135**. As illustrated in FIG. 1, portions **505** and **510** are configured so that they do not protrude when the jaws **105** and **110** are fully closed. In other words portion **505** does not go beyond the bottom of lower jaw **110** and similarly, portion **510** does not go beyond the top of upper jaw **105**.

[0032] Referring back to FIG. 5, also illustrated is a transparent view of surgical punch **100** exposing, in particular, the sliding mechanism **120**, that couples upperjaw **105** to

lower jaw **110**, and the pin **520** and slot **525**, that couples upper jaw **105** to actuating rod **115**. As described above, pin **525** is connected to both upperjaw **105** and actuating rod **115**. As a surgeon actuates actuating rod **115**, causing it to move in a proximal direction as indicated by arrow **530**, pin **520** moves along slot **525**, pulling upper jaw **105** in a proximal direction. As upper jaw **105** moves, its curved groove **120a** rides along flange **120b**, which forms a semi-circular track. Moving along semi-circular flange **120b** causes upper jaw **105** to rotate around projected center of rotation **135**. To accommodate this rotation, slot **525** is also curved, having the same projected center of rotation **135**.

[0033] FIG. 6 illustrates another example of a biting punch **600**. Biting punch **600** includes a stationary upper jaw **605** and a moveable lower jaw **610** attached with a coupling pin **615**. Because the coupling between the jaws is not a sliding mechanism, the center of rotation for lower jaw **610** is at pin **615**. This center of rotation **615** is above the initial cutting point of lower jaw **610**, which is the distal most point of distal portion **620** of cutting edge **625**. Having the center of rotation **615** above the initial cutting point of lower jaw **610** causes the cutting trajectory **625** to be more proximal when jaws **605** and **610** are open than when jaws **605** and **610** are closed. This ensures that the cut at the bottom of meniscus **630** is more proximal than the cut at the top of meniscus **630**. In other words, distance **635** is greater than distance **640**, resulting in a more stable meniscus rim after the surgeon completes the cutting procedure.

[0034] Distal portion **620** of cutting edge **625** has a sharp, negative slope from the distal end to its proximal end. Cutting edge **645** is simply flat across upper jaw **605**. In another example, upper jaw **605** can have a sharp point similar to upper jaw **105**. This configuration causes cutting edge **625** to initially pierce the meniscus **625** at the first point of contact with the tissue, at a location that is distal, with respect to punch **600**, to tear **650**. As jaws **605** and **610** continue to close, the distal end of cutting edge **625** starts to overlap cutting edge **645**. As cutting edge **625** overlaps, this overlap, at the distal ends of jaws **605** and **610** starts at the distal most point of cutting edge **625** and moves proximally, as indicated by arrow **655**. This also means that cutting edges **625** and **645** can cut tissue in a direction from the distal end of punch **600** toward the proximal end, as indicated by arrow **655**.

[0035] A number of embodiments of the invention have been described. Nevertheless, it will be understood that various modifications may be made without departing from the spirit and scope of the invention. For example only and not to limit other alternatives, the grooves on the upper jaw and the flanges on the lower jaw can be reversed so that the upper jaw has flanges and the lower jaw has grooves. The "U" shape of the upper jaw can be different geometries, such as square. The actuating rod can be cylindrical. The coupling mechanism can be completely pinless (e.g., no pin **520**) and include a second groove/flange pair for actuation, such as the one described in U.S. Pat. No. 4,712,545, incorporated herein by reference. A surgeon, or any medical personnel, can use the surgical punch on tissue other than a meniscus. Accordingly, other embodiments are within the scope of the following claims.

What is claimed is:

1. A surgical punch comprising:
 - a first jaw having a first cutting edge;
 - a second jaw having a second cutting edge; and

a coupling member disposed at proximal end portions of the first and second cutting edges, the coupling member configured to bring the first and second jaws towards each other when actuated,

wherein, the jaws are configured to cause cutting from distal ends towards proximal ends of the jaws when the jaws are brought towards each other.

2. The surgical punch of claim 1 wherein a portion of the first cutting edge is disposed distal to the second cutting edge.

3. The surgical punch of claim 1 wherein the first cutting edge further comprises a first distal portion that is closest to the second jaw at a distal end of the first distal portion and farthest from the second jaw at a proximal end of the first distal portion when the first jaw is parallel to the second jaw.

4. The surgical punch of claim 3 wherein the second cutting edge further comprises a second distal portion that is closest to the first jaw at a distal end of the second distal portion and farthest from the first jaw at a proximal end of the second distal portion when the first jaw is parallel to the second jaw.

5. The surgical punch of claim 1 further comprising a projected point of rotation of the cutting located outside of the coupling member.

6. The surgical punch of claim 1 wherein the first jaw is an upper jaw and the second jaw is a lower jaw, the surgical punch further comprising a projected point of rotation of the cutting located above an initial cutting point of the second cutting edge.

7. The surgical punch of claim 1 wherein the first jaw further comprises a leading edge having a reverse slope.

8. The surgical punch of claim 7 wherein the leading edge is further configured to guide the first jaw between a meniscus and a femoral condyle associated with the meniscus.

9. The surgical punch of claim 1 wherein the coupling member comprises a pivot pin.

10. The surgical punch of claim 1 wherein the coupling member comprises a pinless hinge, wherein the first jaw is slidably coupled to the second jaw.

11. The surgical punch of claim 10 wherein the coupling member comprises one of an arcuate flange and an arcuate groove.

12. The surgical punch of claim 10 wherein the coupling member further comprises:

one of the jaws comprising at least one first arcuate flange and the other of the jaws comprising at least one first arcuate groove, the at least one first arcuate flange being slidably disposed in the at least one first arcuate groove so as to pivotally couple the first jaw to the second jaw, whereby the first jaw is capable of pivotal movement towards and away from the second jaw, with the at least one first arcuate flange and the at least one first arcuate groove having a first center of curvature that is fixed in position relative to the second jaw when the at least one first arcuate flange is disposed in the at least one first arcuate groove, and

one of the first jaw and an actuating member comprising at least one second arcuate flange and the other of the first jaw and the actuating member comprising at least

one second arcuate groove, the at least one second arcuate flange being slidably disposed in the at least one second arcuate groove so as to pivotally couple the actuating member to the first jaw, with the at least one second arcuate flange and the at least one second arcuate groove having a second center of curvature that is fixed in position relative to the actuating member and is not fixed in position relative to the second jaw when the at least one second arcuate flange is disposed in the at least one second arcuate groove, and one of the centers of curvature is displaced laterally from the second stationary jaw and the actuating member,

whereby (a) when the actuating member is actuated in a first direction relative to the second jaw, the first jaw will open away from the second jaw, and (b) when the actuating member is moved in a second opposite direction relative to the second jaw, the first jaw will close towards the second jaw, the first and second jaws being arranged so that body tissue located between the first and second jaws may be severed in a punching motion as the jaws are opened and closed relative to one another by actuating the actuating member.

13. The surgical punch of claim 10 wherein the coupling member comprises:

a pin coupled to the first jaw and an actuating member; and

a slot to receive the pin, the slot configured to allow free passage of the pin as the actuating member is actuated.

14. The surgical punch of claim 13 wherein the slot further comprises an arcuate portion.

15. The surgical punch of claim 1 wherein the first jaw is a movable jaw and the second jaw is a stationary jaw.

16. The surgical punch of claim 1 wherein the first jaw is a stationary jaw and the second jaw is a movable jaw.

17. A surgical punch comprising:

a first movable jaw having a first cutting edge and a leading edge including a reverse slope;

a second stationary jaw having a second cutting edge disposed proximal to a portion of the first cutting edge; and

a coupling member slidably coupling the first jaw to the second jaw, the coupling member disposed at proximal end portions of the first and second cutting edges, and configured to bring the first and second jaws towards each other when actuated,

wherein, the jaws are configured to cause cutting from distal ends towards proximal ends of the jaws when the jaws are brought towards each other.

18. The surgical punch of claim 17 wherein the first cutting edge further comprises a first distal portion that is closest to the second jaw at a distal end of the first distal portion and farthest from the second jaw at a proximal end of the first distal portion when the first jaw is parallel to the second jaw.

19. The surgical punch of claim 18 wherein the second cutting edge further comprises a second distal portion that is closest to the first jaw at a distal end of the second distal portion and farthest from the first jaw at a proximal end of the second distal portion when the first jaw is parallel to the second jaw.

20. The surgical punch of claim 17 further comprising a projected point of rotation of the cutting located outside of the coupling member.

21. The surgical punch of claim 17 wherein the first jaw is an upper jaw and the second jaw is a lower jaw, the surgical punch further comprising a projected point of rotation of the cutting located above an initial cutting point of the second cutting edge.

22. The surgical punch of claim 17 wherein the leading edge is further configured to guide the first jaw between a meniscus and a femoral chondyle associated with the meniscus.

23. The surgical punch of claim 17 wherein the coupling member comprises a pinless hinge, wherein the first jaw is slidably coupled to the second jaw.

24. The surgical punch of claim 23 wherein the coupling member comprises one of an arcuate flange and an arcuate groove.

25. The surgical punch of claim 23 wherein the coupling member further comprises:

one of the jaws comprising at least one first arcuate flange and the other of the jaws comprising at least one first arcuate groove, the at least one first arcuate flange being slidably disposed in the at least one first arcuate groove so as to pivotally couple the first jaw to the second jaw, whereby the first jaw is capable of pivotal movement towards and away from the second jaw, with the at least one first arcuate flange and the at least one first arcuate groove having a first center of curvature that is fixed in position relative to the second jaw when the at least one first arcuate flange is disposed in the at least one first arcuate groove, and

one of the first jaw and an actuating member comprising at least one second arcuate flange and the other of the first jaw and the actuating member comprising at least one second arcuate groove, the at least one second arcuate flange being slidably disposed in the at least one second arcuate groove so as to pivotally couple the actuating member to the first jaw, with the at least one second arcuate flange and the at least one second arcuate groove having a second center of curvature that is fixed in position relative to the actuating member and is not fixed in position relative to the second jaw when the at least one second arcuate flange is disposed in the at least one second arcuate groove, and one of the centers of curvature is displaced laterally from the second stationary jaw and the actuating member,

whereby (a) when the actuating member is actuated in a first direction relative to the second jaw, the first jaw will open away from the second jaw, and (b) when the actuating member is moved in a second opposite direction relative to the second jaw, the first jaw will close towards the second jaw, the first and second jaws being arranged so that body tissue located between the first and second jaws may be severed in a punching motion as the jaws are opened and closed relative to one another by actuating the actuating member.

26. The surgical punch of claim 23 wherein the coupling member comprises:

a pin coupled to the first jaw and an actuating member; and

a slot to receive the pin, the slot configured to allow free passage of the pin as the actuating member is actuated.

27. The surgical punch of claim 26 wherein the slot further comprises an arcuate portion.

28. A surgical punch comprising:

an actuating rod;

a first jaw having a first cutting edge;

a pin movably coupling the first jaw to the actuating rod;

a second jaw having a second cutting edge and a slot configured to allow free passage of the pin as the actuating member is actuated; and

a coupling member disposed at proximal end portions of the first and second cutting edges, the coupling member including a flange and a groove configured to bring the first and second jaws towards each other when actuated.

29. The surgical punch of claim 28 wherein the jaws are configured to cause cutting from distal ends towards proximal ends of the jaws when the jaws are brought towards each other.

30. The surgical punch of claim 28 wherein a portion of the first cutting edge is disposed distal to the second cutting edge.

31. The surgical punch of claim 28 wherein the first cutting edge further comprises a first distal portion that is closest to the second jaw at a distal end of the first distal portion and farthest from the second jaw at a proximal end of the first distal portion when the first jaw is parallel to the second jaw.

32. The surgical punch of claim 31 wherein the second cutting edge further comprises a second distal portion that is closest to the first jaw at a distal end of the second distal portion and farthest from the second jaw at a proximal end of the second distal portion when the first jaw is parallel to the second jaw.

33. The surgical punch of claim 28 further comprising a projected point of rotation of the cutting located outside of the coupling member.

34. The surgical punch of claim 28 wherein the first jaw is an upper jaw and the second jaw is a lower jaw, the surgical punch further comprising a projected point of rotation of the cutting located above an initial cutting point of the second cutting edge.

35. The surgical punch of claim 28 wherein the first jaw further comprises a leading edge having a reverse slope.

36. The surgical punch of claim 35 wherein the leading edge is further configured to guide the first jaw between a meniscus and a femoral chondyle associated with the meniscus.

37. The surgical punch of claim 28 wherein the first jaw is a movable jaw and the second jaw is a stationary jaw.

38. The surgical punch of claim 28 wherein the first jaw is a stationary jaw and the second jaw is a movable jaw.

39. A surgical punch comprising:

an upper jaw having a first cutting edge;

a lower jaw having a second cutting edge; and

a coupling member to couple the upper jaw to the lower jaw, the coupling member including a center of rotation, the center of rotation configured to cause a predefined vertical cut in target tissue.

40. The surgical punch of claim 39 wherein the predefined cut is more distal, with respect to the surgical punch, at an end of the tissue closest to the upper jaw than at an end of the tissue closest to the lower jaw.

41. The surgical punch of claim 39 wherein a portion of the first cutting edge is disposed distal to the second cutting edge.

42. The surgical punch of claim 39 wherein the first cutting edge further comprises a first distal portion that is closest to the lower jaw at a distal end of the first distal portion and farthest from the lower jaw at a proximal end of the first distal portion when the upper jaw is parallel to the lower jaw.

43. The surgical punch of claim 42 wherein the second cutting edge further comprises a second distal portion that is closest to the upper jaw at a distal end of the second distal portion and farthest from the upper jaw at a proximal end of the second distal portion when the upper jaw is parallel to the lower jaw.

44. The surgical punch of claim 39 wherein the center of rotation is located outside of the coupling member.

45. The surgical punch of claim 39 wherein the center of rotation is located above an initial cutting point of the second cutting edge.

46. The surgical punch of claim 39 wherein the upper jaw further comprises a leading edge having a reverse slope.

47. The surgical punch of claim 46 wherein the leading edge is further configured to guide the upper jaw between a meniscus and a femoral condyle associated with the meniscus.

48. The surgical punch of claim 39 wherein the coupling member comprises a pivot pin.

49. The surgical punch of claim 39 wherein the coupling member comprises a pinless hinge, wherein the upper jaw is slidably coupled to the lower jaw.

50. The surgical punch of claim 49 wherein the coupling member comprises one of an arcuate flange and an arcuate groove.

51. The surgical punch of claim 49 wherein the coupling member further comprises:

one of the jaws comprising at least one first arcuate flange and the other of the jaws comprising at least one first arcuate groove, the at least one first arcuate flange being slidably disposed in the at least one first arcuate groove so as to pivotally couple the upper jaw to the lower jaw, whereby the upper jaw is capable of pivotal

movement towards and away from the lower jaw, with the at least one first arcuate flange and the at least one first arcuate groove having a first center of curvature that is fixed in position relative to the lower jaw when the at least one first arcuate flange is disposed in the at least one first arcuate groove, and

one of the upper jaw and an actuating member comprising at least one second arcuate flange and the other of the upper jaw and the actuating member comprising at least one second arcuate groove, the at least one second arcuate flange being slidably disposed in the at least one second arcuate groove so as to pivotally couple the actuating member to the upper jaw, with the at least one second arcuate flange and the at least one second arcuate groove having a second center of curvature that is fixed in position relative to the actuating member and is not fixed in position relative to the lower jaw when the at least one second arcuate flange is disposed in the at least one second arcuate groove, and one of the centers of curvature is displaced laterally from the lower jaw and the actuating member,

whereby (a) when the actuating member is actuated in a first direction relative to the lower jaw, the upper jaw will open away from the second jaw, and (b) when the actuating member is moved in a second opposite direction relative to the lower jaw, the upper jaw will close towards the lower jaw, the upper and lower jaws being arranged so that body tissue located between the upper and lower jaws may be severed in a punching motion as the jaws are opened and closed relative to one another by actuating the actuating member.

52. The surgical punch of claim 49 wherein the coupling member comprises:

a pin coupled to the upper jaw and an actuating member; and

a slot to receive the pin, the slot configured to allow free passage of the pin as the actuating member is actuated.

53. The surgical punch of claim 52 wherein the slot further comprises an arcuate portion.

54. The surgical punch of claim 39 wherein the upper jaw is a movable jaw and the lower jaw is a stationary jaw.

55. The surgical punch of claim 1 wherein the upper jaw is a stationary jaw and the lower jaw is a movable jaw.

* * * * *