



US005797918A

United States Patent [19]

[11] Patent Number: **5,797,918**

McGuire et al.

[45] Date of Patent: **Aug. 25, 1998**

[54] **FLEXIBLE SURGICAL SCREWDRIVER AND METHODS OF ARTHROSCOPIC LIGAMENT RECONSTRUCTION**

3,696,694	10/1972	Boro	81/57.27
4,643,052	2/1987	Badiali	81/57.28
4,706,659	11/1987	Matthews et al.	606/80
4,947,942	8/1990	Lightle et al.	173/216
5,069,569	12/1991	Lieser	403/57
5,387,218	2/1995	Meswania	606/80
5,455,997	10/1995	Nasiell	29/456
5,527,316	6/1996	Stone et al.	606/80

[75] Inventors: **David A. McGuire**, 3418 Lakeside Dr., Anchorage, Ak. 99515; **Jeffery W. Lefler**, Corona; **Gary T. Garman**, La Verne, both of Calif.

[73] Assignee: **David A. McGuire**, Anchorage, Ak.

Primary Examiner—Guy V. Tucker
Attorney, Agent, or Firm—Bromberg & Sunstein LLP

[21] Appl. No.: **554,601**

[57] **ABSTRACT**

[22] Filed: **Nov. 6, 1995**

Related U.S. Application Data

A surgical screwdriver for inserting bone screws in bone tunnels in ligament reconstruction has, in a preferred embodiment, a cannulated flexible shaft portion. The flexible shaft portion is formed by a plurality of linkage members disposed in series. Each linkage member is joined to an adjacent linkage member so as to permit adjacent linkage members to be pivotally movable with respect to one another about a pivot axis. The screwdriver is used in methods of arthroscopic cruciate ligament reconstruction including the steps of introducing the screwdriver along a guide wire through a portal that is offset from the longitudinal axis of a bone tunnel and driving an interference screw mounted on the driver in the bone tunnel to fixate a bone block in the bone tunnel.

[63] Continuation-in-part of Ser. No. 340,790, Nov. 16, 1994, Pat. No. 5,464,407, which is a continuation-in-part of Ser. No. 956,733, Oct. 2, 1992, Pat. No. 5,391,170, which is a continuation-in-part of Ser. No. 806,906, Dec. 13, 1991, Pat. No. 5,257,996, and a continuation-in-part of Ser. No. 839,466, Feb. 19, 1992, Pat. No. 5,520,693.

[51] **Int. Cl.⁶** **A61B 17/56**
[52] **U.S. Cl.** **606/104; 81/450; 81/64**
[58] **Field of Search** **606/80, 104, 79, 606/73, 72; 81/442, 450, 64, 65.2**

[56] References Cited

U.S. PATENT DOCUMENTS

2,042,376 5/1936 Balga 279/89

33 Claims, 11 Drawing Sheets

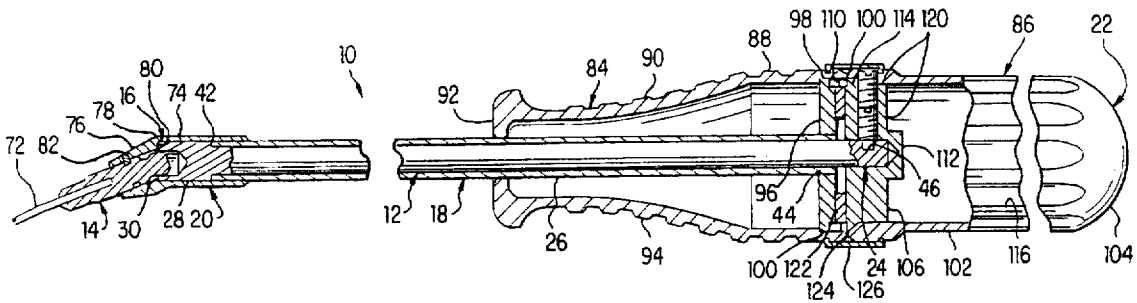

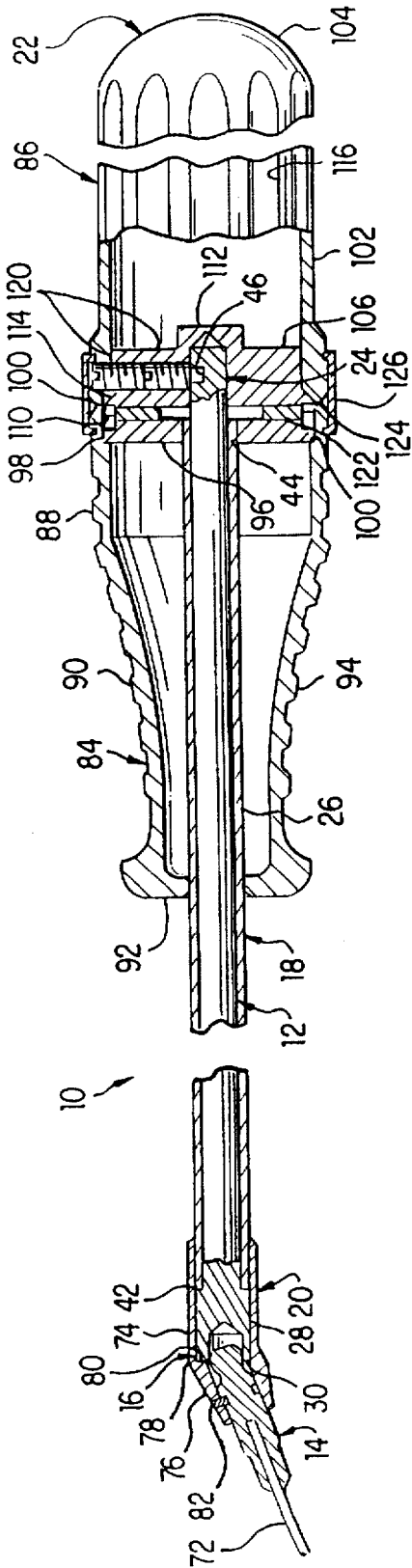

FIG. 1

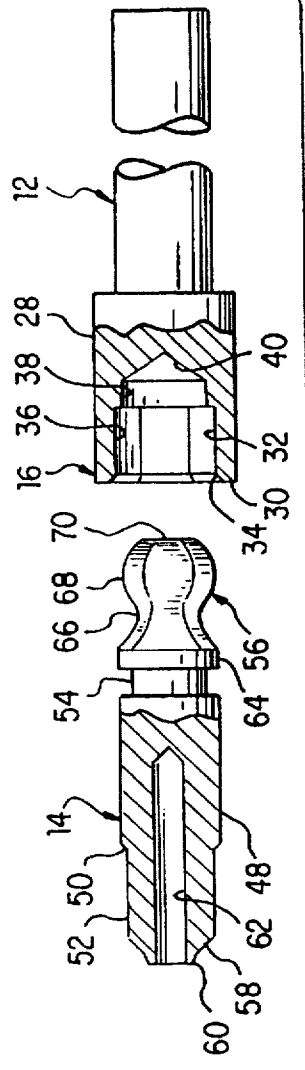

FIG. 2

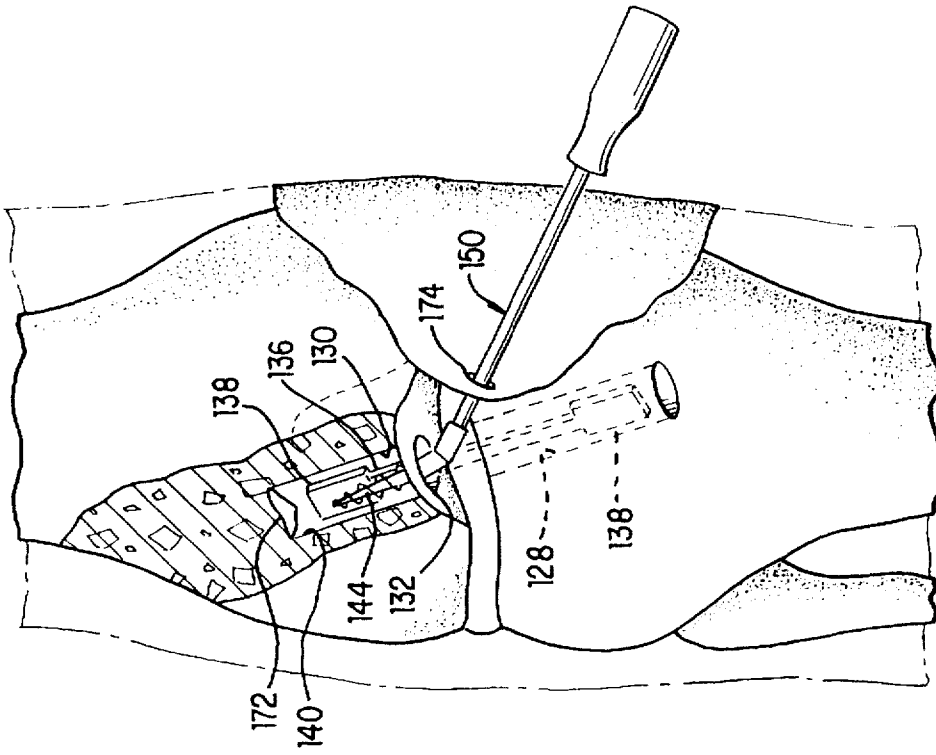

FIG. 5

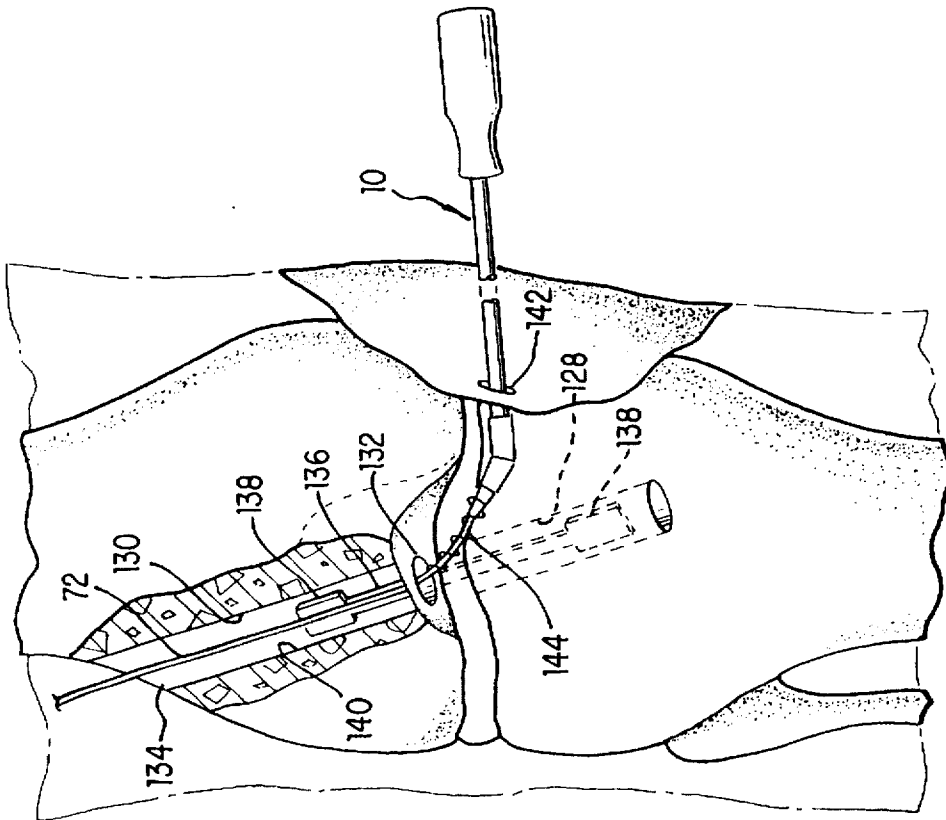

FIG. 3

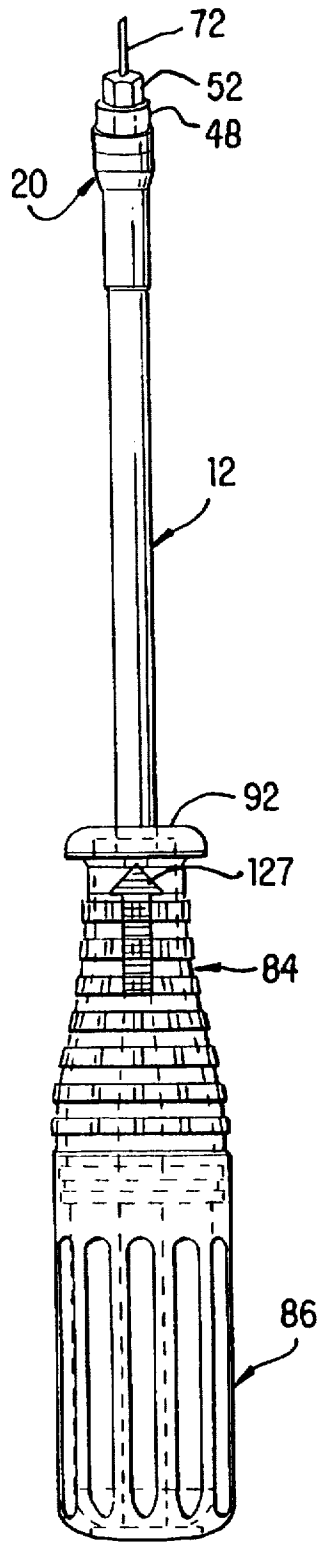

FIG. 3A

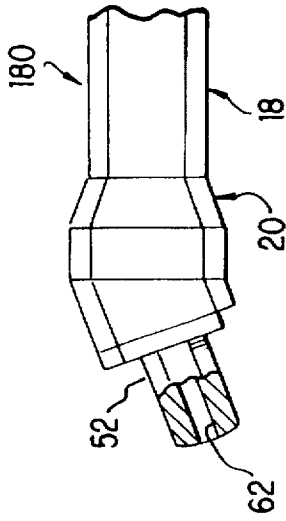

FIG. 7

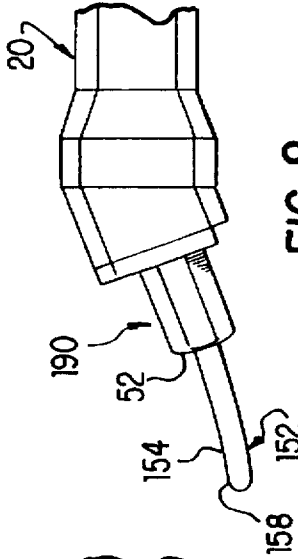

FIG. 8

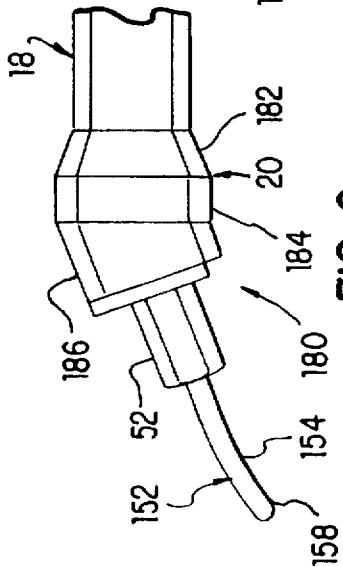

FIG. 6

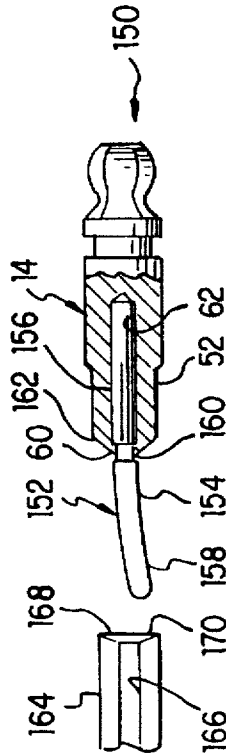

FIG. 4

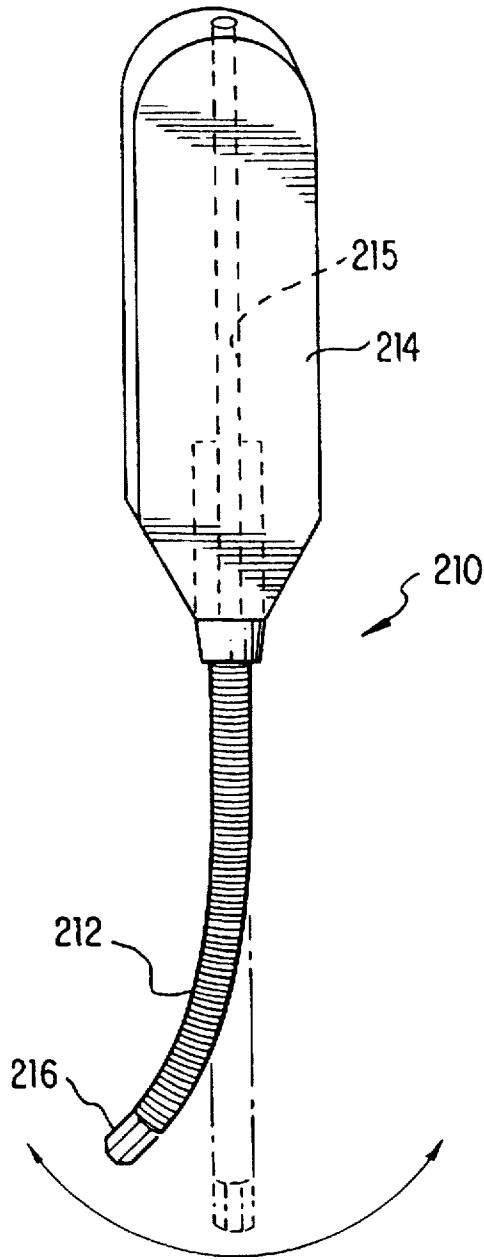

FIG. 9

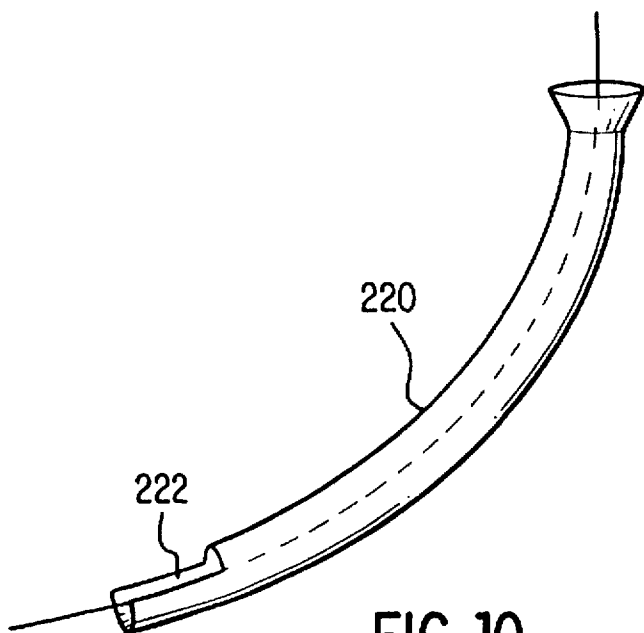

FIG. 10

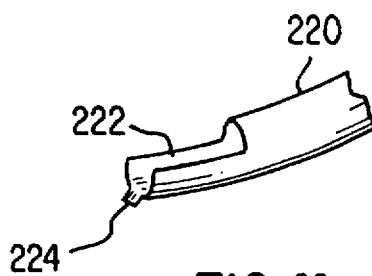

FIG. 11

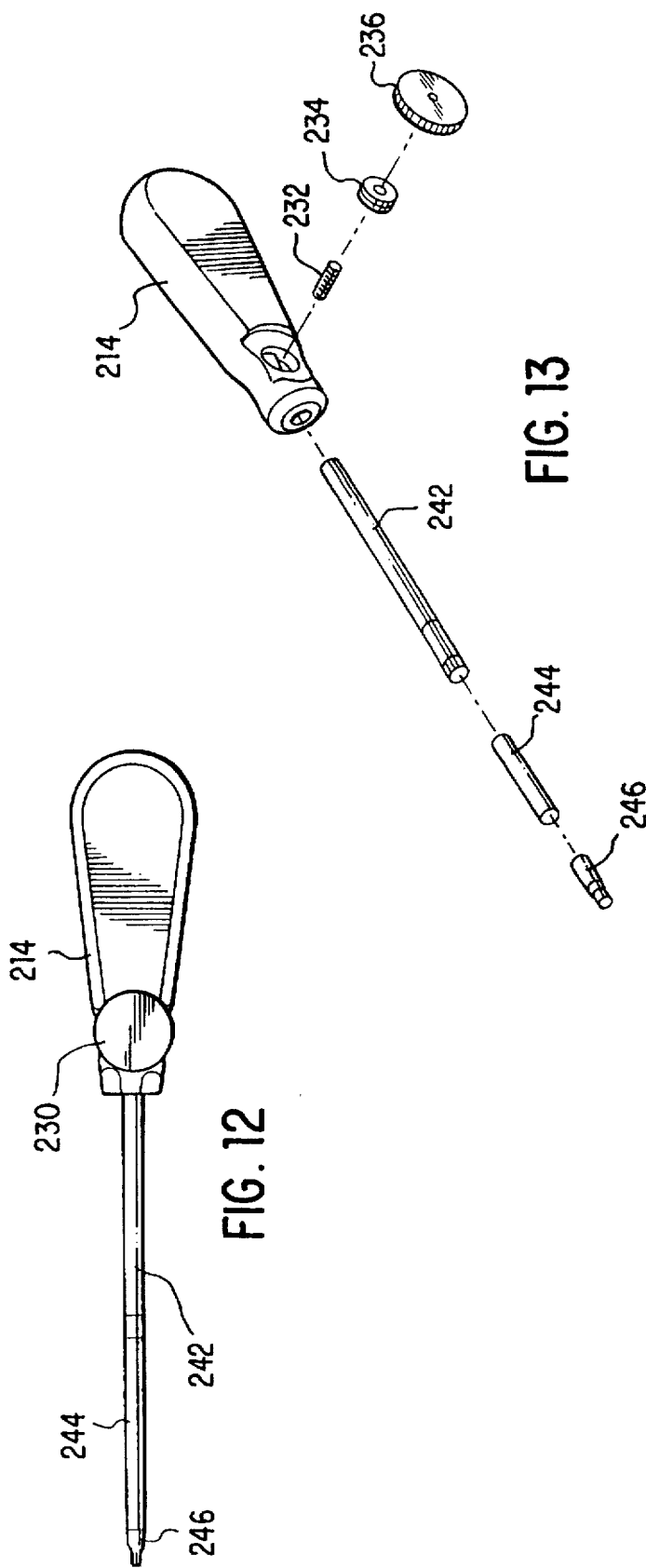

FIG. 12

FIG. 13

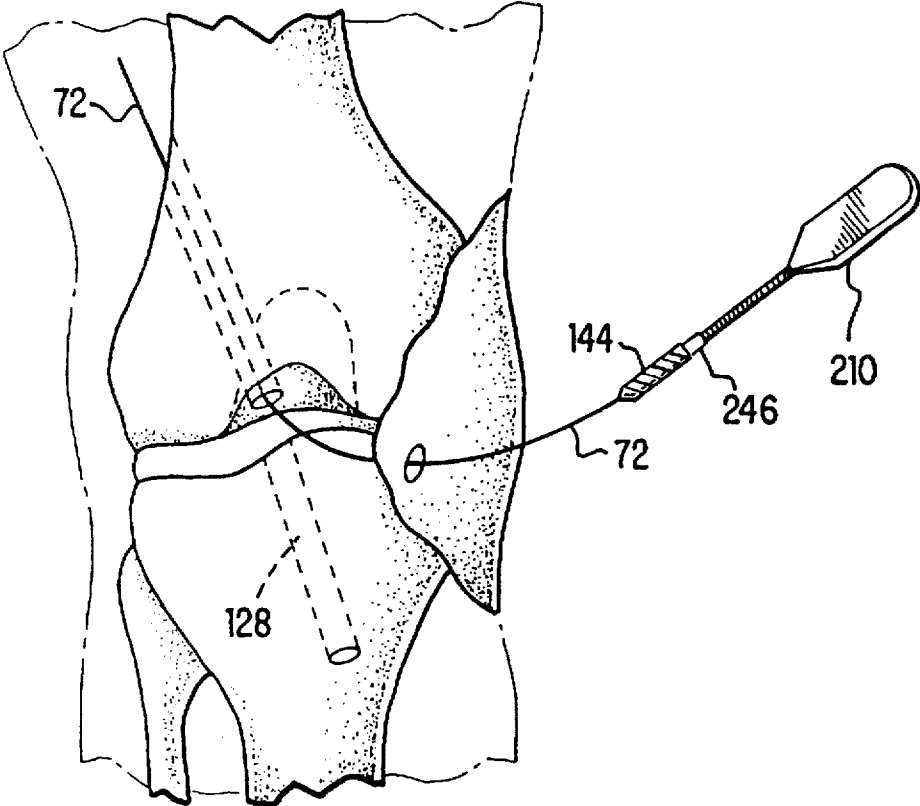

FIG. 14

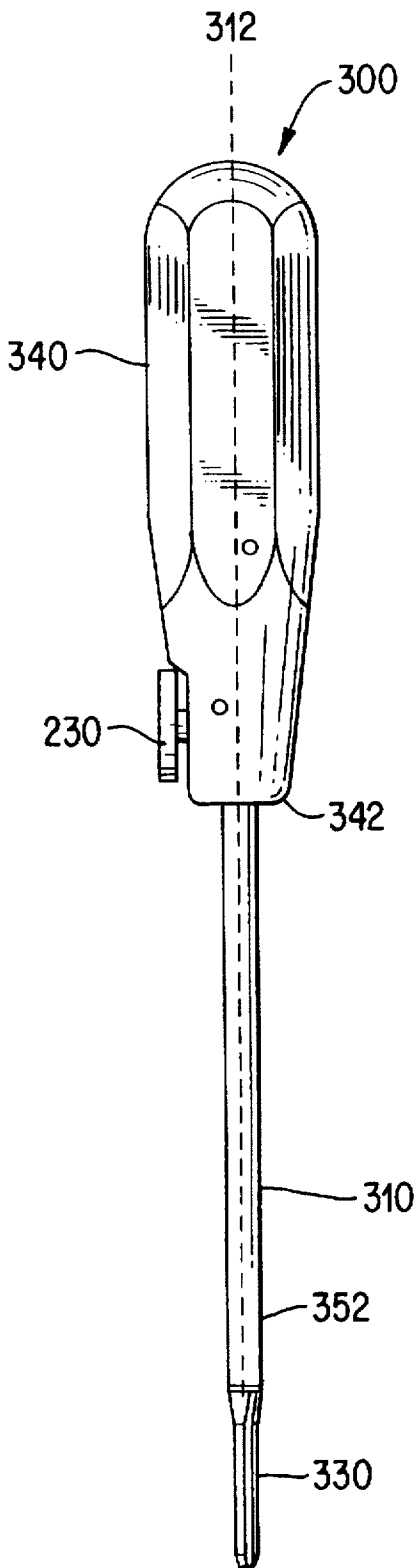

FIG. 15

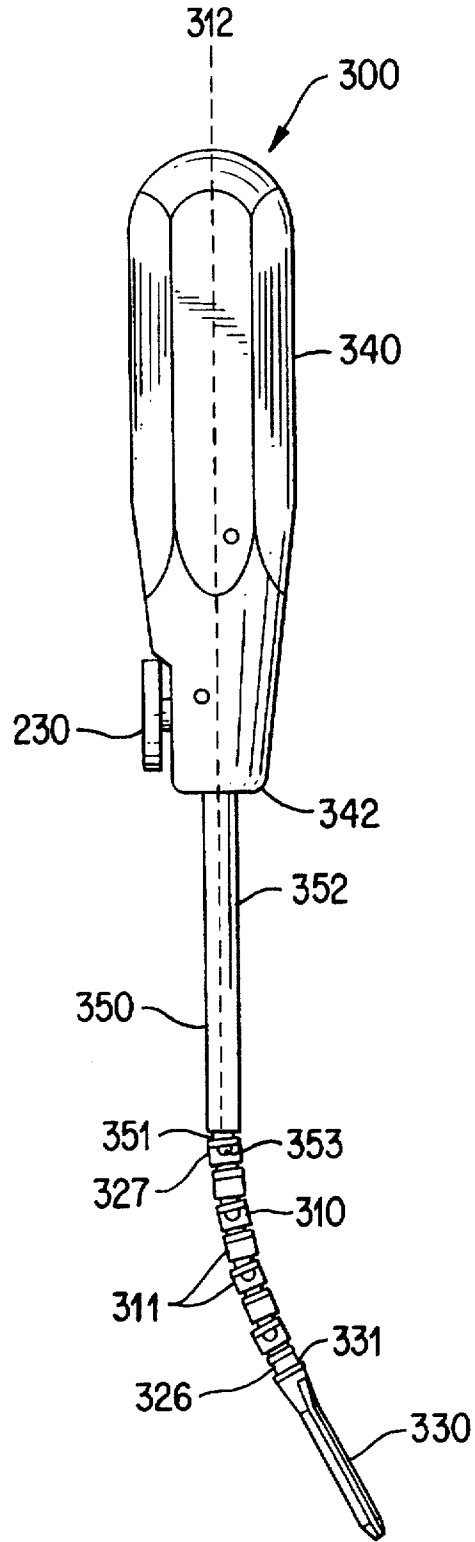

FIG. 16

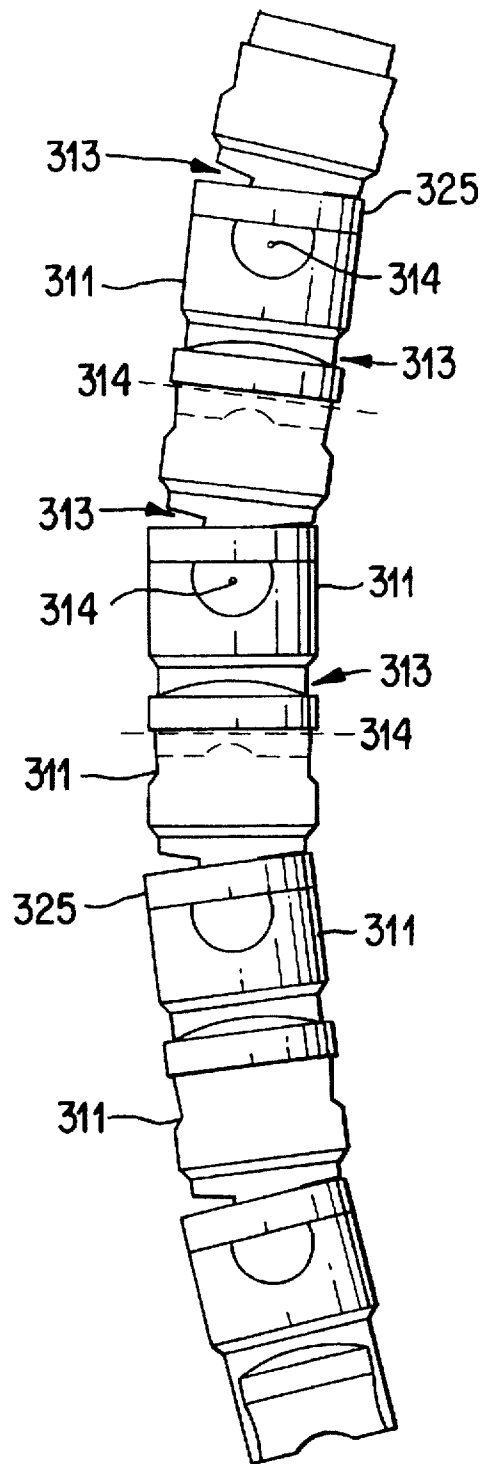

FIG.17

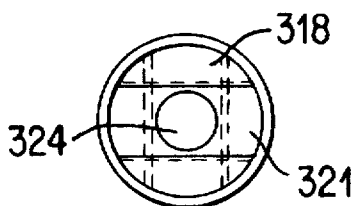

FIG. 18B

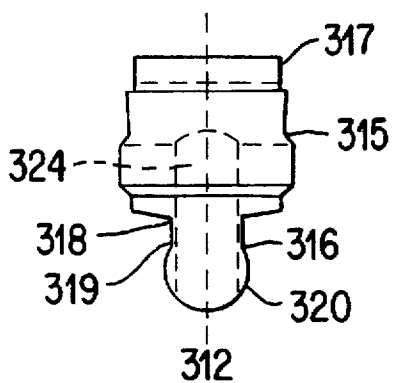

FIG. 18A

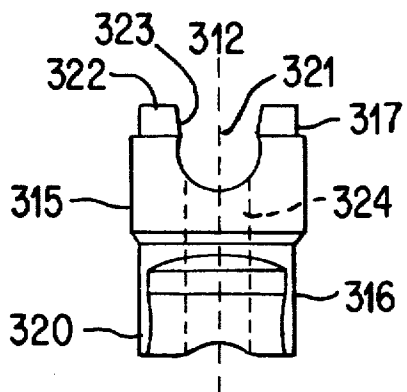

FIG. 19A

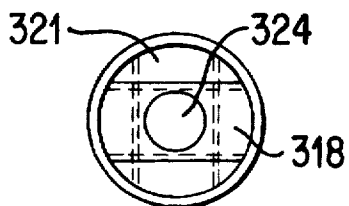

FIG. 19B

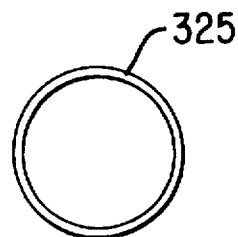

FIG. 20A



FIG. 20B

FLEXIBLE SURGICAL SCREWDRIVER AND METHODS OF ARTHROSCOPIC LIGAMENT RECONSTRUCTION

RELATED U.S. APPLICATION

This application is a continuation-in-part of application Ser. No. 08/340,790, filed Nov. 16, 1994, now U.S. Pat. No. 5,464,407, which is a continuation-in-part of application Ser. No. 07/956,733, filed Oct. 2, 1992 and issued Feb. 21, 1995 as U.S. Pat. No. 5,391,170, which is a continuation-in-part of application Ser. No. 07/806,906, filed Dec. 13, 1991 and issued Nov. 2, 1993 as U.S. Pat. No. 5,257,996, and application Ser. No. 07/839,466, filed Feb. 19, 1992, now U.S. Pat. No. 5,520,693. These related applications are hereby incorporated herein by reference.

TECHNICAL FIELD

The present invention pertains to surgical screwdrivers for inserting bone screws and, more particularly, to surgical screwdrivers for inserting interference bone fixation screws in bone tunnels and to methods of performing arthroscopic cruciate ligament reconstruction of the knee.

BACKGROUND ART

Various surgical procedures utilize devices to fixate anatomical tissue for healing. An example of a fixation device is an interference bone fixation screw, commonly referred to throughout the present description as "interference screw", used to fixate ligaments within bone tunnels during cruciate ligament reconstruction of the knee.

A surgical screwdriver is commonly used to insert bone screws. This form of screwdriver has a rotatable drive shaft for rotating the screw, and advancing it along the longitudinal axis of the driver. The driver cooperatively engages with a drive recess, within the interference screw, to help achieve axial alignment of the screw with the drive shaft of the screwdriver.

In cruciate ligament reconstruction, the interference screw is inserted into tandem isometrically positioned bone tunnels formed in the tibia and femur. A prosthetic ligament graft affixed to bone blocks at each end is inserted into the bone tunnel such that the ligament extends across the knee joint in the anatomical position of the cruciate ligament. The bone blocks are fixated within the bone tunnel by interference screws. Each interference screw is inserted in the bone tunnel so as to be disposed laterally between the walls of the bone tunnel and the bone block. Successful cruciate ligament reconstruction depends on the proper insertion of the interference screw along the longitudinal axis of the bone tunnel, parallel to both the tunnel walls and the bone block. Incorrect insertion of the interference screw causes screw divergence, resulting in increased difficulty in advancing the screw in the bone tunnel and reduced contact between the threads on the screw and the bone block. In addition, screw convergence can result in crushing or fracturing of the ligament and dislocation of the bone block, causing deviation of the ligament from an accurate, pre-established isometric position.

Cruciate ligament reconstruction is commonly performed as an open surgical procedure. Incisions on the order of 10 inches in length are utilized to access the knee joint. These relatively long incisions are required to provide room for the surgical screwdriver to approach the tibial and femoral bone tunnels from directions aligned with the longitudinal axes of the bone tunnels and thereby to permit the driver to drive the

interference screws effectively in a direction parallel with the bone block and the walls of the bone tunnels.

Open surgery possesses numerous disadvantageous compared to closed surgery or less invasive (arthroscopic) surgery for ligament reconstruction. These disadvantages include possible violation of mechanoreceptors in the knee, desiccation of articular cartilage of the joint, increased tissue trauma resulting from incisions accompanied by increased patient discomfort and delayed post surgical mobility. In addition, hospitalization and rehabilitation times may be prolonged.

Accordingly, it is desirable to develop methods for performing cruciate ligament reconstruction that are less invasive, such as arthroscopic surgical procedures. Narrow portals are made with a puncture or stab wound in tissue adjacent to the knee of sufficient size to permit insertion of surgical instruments at the knee joint with the knee being visualized with an arthroscope. An arthroscope is here defined as any instrument for insertion into the cavity of a joint in order to inspect its contents. An example of an arthroscope is a fiberscope, which uses fiber optics to transmit images from the interior of the joint.

A method of arthroscopic cruciate ligament reconstruction can provide many benefits over open surgery, including reduced tissue trauma, decreased patient discomfort, earlier and aggressive range of motion and weight bearing without loss of fixation, reduced rehabilitation time and elimination of hospitalization because the procedures can be performed on an out-patient basis.

The limitations on maneuverability imposed by arthroscopic cruciate ligament reconstruction and the location of the arthroscopic portals in tissue adjacent to the knee mean that conventional drivers with straight drive shafts, which are used for placing interference screws into bone tunnels through incisions during open surgery, are not suited for this procedure.

Indeed, the anteromedial and anterolateral portals are angularly offset from the longitudinal axis of the femoral bone tunnel and therefore the direction of approach from such portals to the femoral bone tunnel to insert an interference screw is angularly offset also. The femoral bone tunnel opens on the femoral condyle at a site near the attachment site of the cruciate ligament. Longitudinal alignment of the screwdriver with the opening of the femoral bone tunnel on the femoral condyle is difficult using conventional surgical drivers when the approach is made through the arthroscopic portals. This in turn presents difficulties in driving the screw parallel with the longitudinal axis of the femoral bone tunnel and the bone block in the tunnel.

Attempting to force the driver into parallelism with the longitudinal axis of the femoral bone tunnel runs a number of serious risks, including the possible breakage of the shaft of the driver at the knee; disengagement of the interference screws from the driver during manipulation and their contact with adjacent knee structures, followed by loss of the interference screw in the knee; and misalignment of the interference screw between the wall of the femoral bone tunnel and the bone block.

One compromise approach to the problem of location of arthroscopic portals is to introduce additional portals specifically for the purpose of inserting interference screws into the bone tunnel. One approach is to insert the interference screw through openings of the femoral bone tunnels on the lateral femoral cortex via portals placed proximally and laterally on the patients' thigh. This approach precludes the

use of blind or closed end femoral bone tunnels. Alternatively, interference screws can be inserted through openings in the femoral condyle after their introduction through the tibial bone tunnels.

Angled drivers have been used in industrial applications as wrenches and screwdrivers, and exemplary of such devices are U.S. Pat. Nos. 4,643,052 to Badiali, 4,620,458 to Schmidek, 3,788,169 to Nakayama, 3,696,694 to Boro, 3,604,486 to Henry, 3,232,151 to Blachowski, 2,042,376 to Balga, 1,428,282 to Glabaznya, 1,398,116 to Root, 1,199,823 to Sadtler, 933,639 to Frink and 877,571 to Larson. In medical applications, angled drivers have been used in power tools such as drills, and U.S. Pat. Nos. 5,041,119 to Frigg et al and 4,947,942 to Lightle et al are illustrative of angled, surgical power drills.

Prior art angled surgical drivers are unsuitable for use in least invasive, or endoscopic, surgical procedures to insert interference screws in bone tunnels directly from portals not aligned parallel with longitudinal axes of the bone tunnels. Moreover, angled surgical drivers in the prior art cannot effectively hold screws captive for insertion into the body through endoscopic size portals.

SUMMARY OF THE INVENTION

The present invention provides, in one embodiment, a flexible surgical screwdriver for driving an interference screw into bone so that the screw is securely supported by the driver until insertion has been completed. The flexible surgical driver permits access from an arthroscopic portal not aligned parallel with a longitudinal axis of the bone tunnel to place the interference screw parallel with the walls of the bone tunnel and the bone block while driving the screw from a direction angularly disposed with the tunnel wall.

One embodiment has a flexible shaft, a handle mounted to the flexible shaft for applying rotational force to the shaft, and a drive head mounted on the flexible shaft. The flexible shaft and handle are cannulated according to an embodiment for use with cannulated interference screws. The cannulated screw and driver are guided over a guide wire into position along the bone tunnel wall.

The flexible shaft may be formed by a plurality of linkage members disposed in series. Each linkage member is joined to an adjacent linkage member so as to permit adjacent linkage members to be pivotally movable with respect to one another about a pivot axis while maintaining the ability to transmit torque upon the rotation of the handle.

An alternative embodiment of a screwdriver in accordance with the present invention permitting access from an arthroscopic portal not aligned parallel with a bone tunnel is an angled driver. The drive shaft is mounted on the operating shaft at an angle of approximately 20° with respect to the longitudinal axis of the operating shaft. An indicator on the handle allows orientation of the drive tip to be identified externally of the body, when the drive tip is inserted in the body through portals of minimal size. The angled driver may be used without being cannulated. In this case, a retaining mechanism for holding a cannulated interference screw captive on the drive shaft prior to screw insertion includes a wire having a proximal cylindrical section secured in a passage in the drive tip aligned with the longitudinal axis of the drive shaft and a distal cylindrical section that protrudes beyond the drive tip to be received in the cannula of the interference screw. The distal cylindrical section of the retaining mechanism is formed with a thermally set, slight curve or kink to hold the screw temporarily in place on the drive tip.

The procedure in accordance with a preferred embodiment of the present invention advantageously eliminates the step of penetrating the lateral femoral cortex and permits a countersink of the screw below the opening of the femoral bone tunnel on the femoral condyle. The procedure can be performed with fewer and smaller portals. In fact, the anteromedial and anterolateral portals formed for procedures preparatory to graft fixation can be utilized to directly insert bone screws in femoral bone tunnels. In addition, hyperflexion of the knee in arthroscopic anterior cruciate ligament reconstruction can be eliminated.

The surgical instrument provided in a preferred embodiment of the invention is designed to avoid drive shaft breakage, loss of interference screws at the knee joint, and to enhance screw insertion and driver positioning. In addition, screw divergence is minimized and maximum thread purchase along the length of the bone block is ensured. The embodiment is of unified construction for easy cleaning and sterilization with right and left knee compatibility. The embodiment employs a lightweight, ergonomic handle providing a balanced feel for the surgeon.

BRIEF DESCRIPTION OF THE DRAWINGS

These and other features of the present invention may be more readily understood by reference to the following description, taken in conjunction with the accompanying drawings, in which:

FIG. 1 is a broken side view, partly in longitudinal section, of an embodiment of an angled surgical screwdriver according to the present invention, showing an interference screw mounted on the screwdriver;

FIG. 2 is an exploded, broken side view, partly in section, of the distal end of the angled surgical screwdriver of FIG. 1;

FIG. 3 is a front view, partly in section, of the joint of a right knee positioned at substantially 90°, showing the angled surgical screwdriver of FIG. 1 approaching an open end femoral bone tunnel via an anterolateral portal;

FIG. 3A is a top view of the angled surgical screwdriver of FIG. 1;

FIG. 4 is a broken side view, partly in section, of the drive shaft of a related embodiment of an angled surgical screwdriver according to the present invention, showing a retaining mechanism on the drive shaft and an end of a forming tool for mounting the retaining mechanism on the drive shaft;

FIG. 5 is a front view, partly in section, of the knee, joint of a right knee positioned at substantially 90°, showing the angled surgical screwdriver of FIG. 4 inserting a bone screw in a closed end femoral bone tunnel via an anteromedial portal;

FIG. 6 is a broken side view of the distal end of a further embodiment of an angled surgical screwdriver according to the present invention;

FIG. 7 is a broken side view, partly in section, of the drive shaft for the angled surgical screwdriver of FIG. 6;

FIG. 8 is a broken side view of the distal end of another embodiment of an angled surgical screwdriver according to the present invention;

FIG. 9 is an isometric view of a cannulated flexible screwdriver of the present invention;

FIG. 10 is an isometric view of a curved cannula for use with the screwdriver of FIG. 9;

FIG. 11 is a broken view of an alternate embodiment of the curved cannula of FIG. 10;

FIG. 12 is a plan view of a further embodiment of a cannulated flexible screwdriver of the present invention;

FIG. 13 is an exploded view of the screwdriver of FIG. 12;

FIG. 14 is a front view, partly in section, of the joint of a knee, showing the screwdriver of FIG. 9 approaching a femoral tunnel via a curved cannula inserted through an anterolateral portal;

FIG. 15 is an isometric view of a cannulated flexible screwdriver in accordance with another embodiment of the present invention;

FIG. 16 shows the screwdriver of FIG. 15 in a flexed position;

FIG. 17 is an isometric view of a flexible shaft portion for use with the screwdriver of FIG. 15;

FIG. 18A is a side view of a linkage member of the flexible shaft portion shown in FIG. 17;

FIG. 18B is a top end view of the linkage member shown in FIG. 18A;

FIG. 19A is an alternate side view of the linkage member shown in FIG. 18A having been rotated by 90 degrees about its longitudinal bore;

FIG. 19B is a bottom end view of the linkage member shown in FIG. 19A;

FIGS. 20A-B show a ring for use with the flexible shaft portion shown in FIG. 17.

DESCRIPTION OF SPECIFIC EMBODIMENTS

An angled surgical screwdriver 10 according to an embodiment of the present invention is illustrated in FIG. 1, and includes an elongate operating shaft 12 with a distal end 16 coupled to a drive shaft 14 and a proximal end 24 on which is mounted a movable portion of handle 22. Concentrically disposed around the operating shaft 12 is a sleeve 18, having a distal end 42, on which is mounted a drive head housing 20 and a proximal end 44 secured in a fixed portion of handle 22. Turning the movable portion of handle 22 with respect to the fixed portion thereof causes rotation of the drive shaft 14, which is disposed at an angle of approximately 20° from the axis of rotation of handle 22. The operation of the screwdriver 12 is described in further detail below.

The operating shaft 12 is preferably made of stainless steel with a cylindrical body terminating, at the distal end 16, at a distal end wall 30. Fitted concentrically around the distal end 16 is a cylindrical barrel 28, detail of which is shown in FIG. 2. A socket 32 is formed distally in barrel 28 in axial alignment with a longitudinal axis of the operating shaft 12 and, therefore, the longitudinal axis of the driver 10, as shown in FIGS. 1 and 2.

Socket 32 includes successively a tapered distal recess 34 at end wall 30, an intermediate recess 36, having a hexagonal configuration in cross-section, a cylindrical recess 38, and a conical proximal recess 40. The recesses are contiguous. Intermediate recess 36 is formed of six flat sides extending longitudinally in the barrel 28 from distal recess 34 to cylindrical recess 38. The cylindrical recess 38 has a diameter smaller than the diametric, cross-sectional dimension of the intermediate recess 36.

A ball mechanism 56 includes a cylindrical flange 64 joined to cylindrical neck 54, a curved neck 66 extending proximally from flange 64, and a ball 68 mounted on curved neck 66. The cylindrical flange 64 has an outer diameter that is substantially the same as the outer diameter of the

cylindrical body 48 and larger than the diameter of the cylindrical neck 54, such that an annular recess is defined concentrically around the cylindrical neck 54 laterally between the body 48 and the flange 64 of the drive shaft 14.

The ball 68 has a hexagonal configuration in cross-section, being formed of six curved surfaces extending proximally from curved neck 66 to an end surface 70. Ball 68 is configured to be received in socket 32 of the operating shaft 12 with the longitudinal axis of the drive shaft 14 disposed at an acute angle of approximately 20° with respect to the longitudinal axis of the operating shaft 12. Engagement of the ball 68 in the socket 32 causes rotation of the drive shaft 14 in response to rotation of the operating shaft 12.

Drive shaft 14 is preferably made of stainless steel and, as shown in FIGS. 1 and 2, includes a cylindrical body 48, a drive tip 52, and the ball mechanism 56, in axial alignment. The cylindrical body 48 is joined to the drive tip 52 at the distal end of a shoulder 50 tapered in a distal direction, the proximal end of shoulder 50 joining a neck 54, which in turn proximally joins the cylindrical body 48 to the ball mechanism 56. The drive tip 52 has a distally tapered shoulder 58 terminating distally at an annular, peripheral lip 60, and a cylindrical passage 62 is formed in the drive tip 52 to extend proximally, longitudinally from lip 60 in axial alignment with the longitudinal axis of the drive shaft.

One purpose of the drive tip 52 is to frictionally secure the end of a length of guide wire 72, such as a nickel-titanium alloy wire, as will be explained below, as shown in FIG. 1. Another purpose of the drive tip is to frictionally engage a screw. The drive tip 52 has an external configuration to frictionally engage a drive recess 143 of an interference bone fixation screw 144. The drive tip 52 can have various cross-sectional configurations—for example, multi-lobed or pronged, or hexagonal—corresponding to the configuration of the drive recess 143 of the fixation screw 144, so the screw will be rotated in bone with rotation of the drive shaft 14.

The cylindrical body 48 may be formed with the same cross-sectional configuration as, but slightly greater dimensions than, the drive tip 52, so as to frictionally engage the drive recess 143 of the screw 144, when, as shown in FIG. 1, the drive tip 52 is inserted deeply enough into the screw 144 to cause the body 48 portion to enter the drive recess 143.

In a preferred embodiment, the drive shaft 14 is prevented from being inserted into the drive recess 143 so far that the drive head housing 20 contacts the proximal end of screw 144. In this embodiment, the back end of the screw 144 is spaced distally from the drive head housing 20 to allow a portion (approximately 5 mm in one preferred embodiment) of the drive shaft 14 beyond the drive head housing 20 to be exposed. The exposed portion permits the screw 144 to be countersunk into a bone tunnel by an approximate additional amount equal to the length of the exposed portion.

The back end of the screw can be made to terminate distally of the drive head housing 20 in various ways. These include (a) making the distance from the lip 60 to the drive head housing 20 less than the length of the drive recess 143; or (b) forming the drive shaft 14 with external configurations or diametric dimensions limiting the distance that the drive shaft 14 can be inserted in the drive recess 143; or (c) providing a retaining mechanism on the drive shaft 14 that limits the distance that the drive shaft 14 can be inserted in the drive recess 143 as will be explained further below.

Drive head housing 20 is preferably made of stainless steel and includes a cylindrical section 74 and a distally

tapered nose section 76 joined to the cylindrical section 74 at a bend 78, the nose section 76 extending angularly, distally from the cylindrical section 74. The wall of the cylindrical section 74 has a thickness that is substantially constant along the length of the cylindrical section with an inner diameter sized to closely receive the outer diameters of the cylindrical barrel 28 and the sleeve 18. The wall of the nose section 76 has a thickness that is greater than the wall thickness of the cylindrical section 74 at bend 78 to define an internal shoulder 80 serving as a stop for cylindrical barrel 28 when operating shaft 12 is disposed within the cylindrical section 74. The wall thickness of the nose section 76 tapers in a distal direction such that an internal, cylindrical passage of substantially constant cross-section is defined along the length of the nose section. The cylindrical passage of the nose section 76 is disposed at an angle with respect to the longitudinal axis of the cylindrical passage of the cylindrical section 74 that the angle of the drive shaft 14 with respect to the operating shaft 12.

A C-shaped clip 82 is mounted (by welding, for example, or simply by appropriate dimensions) in an annular slot in the nose section 76 and is received in the annular recess around neck 54 to prevent axial movement of the drive shaft 14 while allowing the drive shaft to rotate within the housing 20.

In a related embodiment of the angled surgical screw-driver shown in FIGS. 4, 6 and 8, the angled driver 150 is substantially the same as the angled driver 10 of FIG. 1, except that a retaining mechanism 152, for holding an interference bone fixation screw captive on the driver prior to insertion of the screw, is mounted on drive shaft 14. Retaining mechanism 152 includes a length of wire 154 (identified in FIGS. 6 and 8), such as a nickel-titanium alloy wire, having a proximal cylindrical section 156, which is joined to neck 160 at a shoulder 162, and a distal cylindrical section 158 joined to the proximal cylindrical section 156 by neck 160.

The neck 160 has an outer diameter that is smaller than the outer diameters of the proximal and distal cylindrical sections, which in turn are slightly smaller than the diameter of the cannula 145 in the interference bone fixation screw 144. The outer diameter of the proximal cylindrical section 156 is sufficient to be received in the passage 62 in the drive tip 52 of drive head 14. The distal cylindrical section 158 is formed with a thermally set, slight radius curve along its length. The length of the wire 154 that protrudes beyond the drive tip 52 when the proximal cylindrical section 156 is received therein is selected to allow the curved distal cylindrical section 158 to be disposed in the cannula 145 of the screw 144 and to provide frictional engagement with the walls forming the cannula 145 when the screw is placed upon the drive shaft 14, such as shown in FIG. 8.

The wire 154 is mounted on the drive shaft 14 by press fitting the proximal cylindrical section 156 in the passage 62 of the drive tip 52 in a manner such that the neck 160 is aligned with edge 60 of drive tip 52. In some instances, depending on the material from which tip 152 is made, a press fit is sufficient and there is no need for neck 160 or shoulder 162. In other instances, when a neck and shoulder structure is used, a forming tool 164 is useful.

Forming tool 164 has a longitudinal cavity 166 terminating at a recess 168 tapered in the distal direction. In use, the forming tool 164 is moved along the wire 154 in the direction of the drive shaft 14 until the end wall 170 abuts the drive tip 52. In that position, the forming tool is urged against the tip 52, and the forming tool's tapered recess 168

forces the lip 60 to grip neck 160, and this grip, along with the shoulder 160, prevent the wire 154 from falling out of the drive shaft 14.

The retaining mechanism 152 may be used on drivers having drive tips axially aligned with longitudinal axes of the drivers to hold a screw upon the drivers prior to screw insertion, and the retaining mechanism 152 is not limited to use with angled drivers. The retaining mechanism 152 may also be constructed in such a way that the fit of the wire 154 in the cannula 145 of screw 144 limits the depth that the drive shaft 14 may be inserted into the drive recess 143.

The proximal end 24 of the operating shaft 12 extends beyond the proximal end 44 of the sleeve 18. A cylindrical aperture 46 to receive a set screw is formed in the proximal extension and is disposed radially with respect to the longitudinal axis of the operating shaft 12.

The sleeve 18 has an outer diameter substantially the same as the outer diameter of barrel 28 at the distal end of the sleeve to form a smooth external profile with the barrel. The sleeve 18 has an inner diameter sized to closely receive the outer diameter of the operating shaft 12 while still permitting the operating shaft 12 to rotate relative to the sleeve 18.

Handle 22 is preferably made of stainless steel and includes a forward static handle section 84, securing sleeve 18, and a rearward movable handle section 86, rotatable relative to the forward section 84.

Forward handle section 84 is of hollow construction and has a cylindrical wall 88 defining an open proximal end and a tapered wall 90 distally joined to cylindrical wall 88 and terminating at a front wall 92. Wall 90 is tapered in a distal direction and is flared adjacent to front wall 92 to define an external profile that facilitates grasping during use. Concentric ribs 94 are provided along an external surface of the forward handle section 84 to facilitate gripping during use. A cylindrical bushing 96 is disposed in the open proximal end of the forward handle section 84. The bushing 96 has an annular, peripheral flange 98 at a forward face thereof abutting an internal annular shoulder 100 of the cylindrical wall 88. A central opening is formed in bushing 96 for securing the proximal end 44 of the sleeve 18 therein. Bushing 96 and sleeve 18 are preferably welded to the forward handle section 84 to form a sealed, water-tight cavity.

Rearward handle section 86 is of hollow construction, having a cylindrical wall 102 defining an open distal end that is closed by end cap 104. A cylindrical bushing 106 is disposed in the open distal end of the rearward handle section 86. The bushing 106 has an annular, peripheral flange 108 at a forward face thereof, and annular rim 110, extending axially in a direction distal from the flange 108, and a central, cylindrical protrusion 112 extending in a proximal direction. The bushing 106 is axially disposed in the open face front end of the rearward handle section 86 with flange 108 abutting an internal shoulder 114 of cylindrical wall 102. An axial cavity is formed in bushing 106, extending proximally from the forward face thereof into the protrusion 112, for mounting the proximal end 24 of the operating shaft 12. Bushing 106 is preferably welded to the rearward handle section 86 to form a sealed, water-tight cavity. Longitudinal ridges 116 are provided along an external surface of the rearward handle section 86 to facilitate gripping during use. A pair of set screws 120 is used to couple the rearward handle section 86 to the operating shaft 12. The screws are disposed in a cylindrical passage formed in the bushing 106, radially disposed with respect to the

longitudinal axis of the operating shaft 12 and in communication with the axial cavity of the bushing, the cylindrical passage being aligned with an opening in the cylindrical wall of 102 of the rearward handle section 86.

The forward handle section 84 is assembled with the rearward handle section 86, in such a way that the cylindrical wall 88 within the distal end of the forward handle section 84 abuts the cylindrical wall 102 of the rearward handle section 86 at a junction 124. A ring 126, preferably made of stainless steel, is disposed concentrically around the handle 22 to extend over the junction 124, the ring 126 being mounted in grooves in the forward and rearward handle sections, while creating a stainless to stainless bearing surface that minimizes friction between the relatively movable components of the handle 22, to provide a good tactile response during use. A thrust washer 122 is disposed concentrically within rim 110 abutting the forward face of the bushing 106 such that the rearward handle section 86 can be assembled with the forward handle section 84 with the thrust washer 122 abutting a rearward face of bushing 96 and rim 110 extending along the cylindrical wall 88 within the distal end of the forward handle section 84.

Handle 22 is of lightweight, ergonomic construction to provide a balanced feel for a surgeon during use. During use, upon rotation of the rearward handle section 86 relative to the forward handle section 84, the operating shaft 12 will be rotated relative to sleeve 18, causing rotation of drive shaft 14 and the drive tip 52.

As shown in FIG. 3A, indicator 127, here an arrow, is provided along an external surface of the forward handle section 84 to indicate, from a position external of the body, the orientation of the drive tip 52 when inserted in the body through an endoscopic portal. The indicator 127 is disposed on the same side of handle 22 as the drive tip 52 and is aligned with the drive tip 52 and the longitudinal axis of the surgical screwdriver 10 such that, with the indicator 127 facing a surgeon, the drive tip 52 will be oriented in a direction angularly upward relative to the longitudinal axis of the surgical screwdriver. The indicator 127 may utilize a wide range of suitable symbols, including arrows, lines or dots, and may be formed on the handle in diverse ways, such as by laser etching, engraving, or chemical deposition. Where formed as an indentation in the surface of the forward handle section 84, the indicator 127 can provide a tactile, as well as a visual, indication of the position of the drive tip 52.

The angled driver of the embodiment described herein includes numerous design features that facilitate its use in arthroscopic anterior cruciate ligament reconstruction. At the drive tip, the walls of the cylindrical section 74 and the nose section 76 have a minimal thickness to reduce the overall outer diameter of the angled surgical screwdriver 10 in the area of bend 78, and the distance that the angled surgical screwdriver 20 protrudes distally beyond bend 78 is minimized to enhance maneuverability of the driver within the close confines of the knee joint and to allow the use of smaller portals in arthroscopic cruciate ligament reconstruction. The minimal diametric dimension and distal taper of the nose section facilitate insertion of the driver in bone tunnels, allowing the drive shaft 14 to be inserted in bone tunnels up to bend 78. Shoulders 50 and 58 give the drive head 14 a distal taper, facilitating insertion in portals of minimal size and additionally enhance maneuverability at the knee joint. The drive shaft 14 protrudes beyond the back end of the bone screw 144 and spaces the bone screw distally from the bend 78 a greater amount, such that the bone screw can be inserted that much further into a bone tunnel with the driver inserted in the bone tunnel up to the bend 78.

According to a preferred embodiment, the outer diameter of the angled driver 10 at bend 78 is approximately 0.350 inches (8.9 mm), and the distance that the driver protrudes distally of bend 78 is approximately 0.710 inches (18.0 mm).

In accordance with the present invention, an angled surgical screwdriver can be achieved by providing a flexible drive shaft. In addition, the capability of guiding the angled screwdriver along a guide wire may be made possible by providing a cannulation through the drive shaft and the handle of the screwdriver. Referring now to FIG. 9, a flexible cannulated screwdriver 210 is shown. A flexible drive shaft 212 may be formed by two or more concentric wire coils. The coils are wound in opposite directions, one being clockwise and another counterclockwise. The coils advantageously leave a tunnel through the center of the shaft through which a guide wire may be inserted. A handle 214 is attached to one end of the drive shaft. The handle 214 has a longitudinal tunnel or cannula 215 in alignment with the tunnel through the flexible shaft 212. At the distal end of the drive shaft 212, a drive tip 216 is mounted. The drive tip 216 is configured to engage a drive recess or drive protrusion at the rear of a screw. The drive tip 216 is cannulated to receive a guide wire that will pass through the shaft and handle of the driver. The spiral coils are advantageously flexible so that the drive shaft can assume a wide range of angles for driving a screw into its desired location. By providing two oppositely wound coils, the screwdriver can be used to transmit rotational movement in either a clockwise or counterclockwise direction. In one rotational direction, one of the coils tightens and rotates the drive head. In the opposite rotational direction, the other spiral coil tightens and rotates the drive head in the opposite rotational direction. If the screwdriver is to be used only for rotation in a single direction, it would be sufficient to use a single spiral coil. Moreover, other materials beside spiral coils may provide the requirements of flexibility and rotational stiffness. For example, the shaft may possibly be formed by a Nickel-titanium alloy tube. Therefore, the use of such other materials and constructions as are well known to those of ordinary skill in the art are included for use within the scope of the present invention of a flexible cannulated surgical screwdriver.

A curved sheath 220 may be used in conjunction with the guide wire to assist in protecting surrounding tissue from the screw threads. In accordance with a presently preferred embodiment of the curved sheath 220, an opening or slot 222 is provided at the distal end of the sheath to permit direct visualization of the screwdriver tip as it enters the bone tunnel.

The curved sheath may be modified as shown in FIG. 11 to add a sharp flange 224 projecting from the distal end of the curved sheath away from the sheath. The sharp flange 224 may be dug into a bone portion of the graft so as to hold the graft in place during interference screw fixation.

In accordance with a presently preferred embodiment of the cannulated flexible screwdriver of the invention, reference now is made to FIGS. 12 and 13. The handle 214 is designed to give the surgeon enough leverage to apply sufficient torque upon an interference screw. However, care is taken in designing the handle to help avoid application of too much torque. For example, the handle on a driver for bio-absorbable screws is made narrower because such screws cannot withstand as much torque as a stainless steel screw. The presently preferred handle dimensions for driving steel screws are $\frac{3}{4}$ inches (2 cm) thick and $1\frac{1}{2}$ inches (3.8 cm) wide at its widest portion. The choice of dimensions depends upon the type of screw to be used with the driver.

An optional locking screw **230** may be provided on the handle for clamping onto the guide wire when it is within the cannula of the driver. This can be helpful in removing the guide wire from the bone tunnel after the interference screw has been properly secured between a bone graft and the bone tunnel wall. After the screwdriving procedure is completed, the locking screw **230** may be tightened against the guide wire. Then by pulling on the handle of the screwdriver the guide wire is removed from the bone tunnel. The locking screw **230** may be made in several parts for ease of manufacture. A threaded screw **232** is held within a bushing **234**. A knob **236** attaches to the bushing to facilitate manual rotation of the screw.

The screwdriver shaft may also be formed out of several parts. Secured to the handle in the embodiment of FIG. 12 is a stiff cannulated shaft **242**. The stiff shaft **242** may be made from stainless steel. A counterbore is provided at the distal end of the stiff shaft for accepting the flexible members **244**.

The flexible member **244** of the present embodiment is formed by four concentric coil springs. The concentric coil springs fit closely over one another. This prevents a windup delay in the transmission of torque when the handle is rotated. The concentric coil springs alternate from innermost to outermost between clockwise and counterclockwise helices. While the clockwise springs tighten and transmit torque, the counterclockwise springs open up. When the driver is rotated in the opposite direction, the counterclockwise springs tighten while the clockwise springs open. If the pitch of the coils is small as in the case for a single wire, the coils might interengage during application of torque. To prevent this, each spring is made with from about three to ten wires. The wires are wound in parallel to form a helix of a single diameter. The reason a plurality of wires is used in each spring is to give the wires of the spring a steeper pitch. With the steeper pitch, during application of torque, adjacent concentric springs will hit against each other with wire strands roughly at right angles to one another. When the inner spring expands, the outer spring contracts. The pitched wires prevent interengagement while permitting torque transmission.

The proximal end of the flexible member **244** is soldered or attached by some other conventional method within the counterbore of the stiff shaft **242**. The distal end of the flexible member **244** is soldered or otherwise attached to a drive tip **246**. The drive tip **246** has a head, as described above for the angled driver, shaped for engagement with the proximal end of a screw. The drive tip **246** of the flexible driver is cannulated for fitting over a guide wire.

About the outside of the flexible member **244** is a heat shrunk plastic tube. The plastic tube is preferably made from an autoclavable material.

In a further embodiment of the present invention, flexible cannulated screwdriver may be achieved with a flexible shaft portion having a plurality of linkage members. FIGS. 15 and 16 show a flexible cannulated screwdriver **300**, including a flexible shaft portion **310** having a plurality of linkage members **311** being disposed in series. Each linkage member **311** is designed to be pivotally movable with respect to an adjacent linkage member so as to permit the flexible shaft portion **310** to conform generally to a curvature along a longitudinal axis **312**, or alternatively, to assume a straight configuration. As can be seen in FIG. 15, the flexible shaft portion **310** is attached at its distal end to a drive tip **330** and at its proximal end to a handle **340**. The drive tip **330** and handle **340** may be configured in the

manner of the handles and drive tips described above. Thus, the handle **340**, for example, may be provided with a locking screw **230** as in FIG. 12. In accordance with one embodiment of the present invention, the drive tip **330** and the flexible shaft portion **310** are cannulated so that a guide wire may extend up through the drive tip **330** and into the flexible shaft portion **310** when the screwdriver **300** is being used to secure an interference screw between a bone graft and a bone tunnel wall.

Referring now to FIG. 17, each linkage member **311** is joined to an adjacent linkage member via a link **313** so that each linkage member **311** may pivot about an axis **314**. The pivot axis **314** for each linkage member **311** is transverse to a longitudinal bore **324** (shown in FIGS. 18A, 18B, 19A, and 19B). However, as can be seen in FIG. 17, each pivot axis **314** also is disposed at an angle (preferably 90 degrees) with respect to the pivot axis of an adjacent linkage member **311**. By providing adjacent linkage members **311** with pivot axes **314** that are perpendicular with respect to one another, the flexible shaft portion **310** can be made to conform to a desired curve while maintaining the ability to transmit torque upon rotation of the handle **340** so as to rotate the drive tip **330** in either a clockwise or a counterclockwise direction.

A linkage member **311** for use with the flexible shaft portion **310** of the present invention is shown in FIGS. 18A-B and 19A-B. It should be noted that whereas FIG. 18A illustrates a side view of the linkage member **311** from one perspective, FIG. 19A illustrates an alternate side view of the same linkage member **311** having been longitudinally rotated 90 degrees about the axis **312** from the position shown in FIG. 18A. The linkage member **311**, being generally cylindrical in shape, is formed with a body segment **315**, a male end **316**, and an opposing female end **317** adapted to engage a male end of an adjacent linkage member **311**. The male end **316**, when viewed from the perspective of FIG. 18A, comprises a tongue **318** lying generally in a first plane parallel to the longitudinal bore **324**. Tongue **318** projects from the body segment **315** and includes constriction **319** and terminates in a cylindroidal lip **320**. The lip **320**, when viewed from the perspective of FIG. 19A, is a cylindroidal member extending substantially across the entire diameter of the body segment **315**.

With particular reference to FIG. 19A, the female end **317** includes a channel **321** defining a second plane that is also parallel to the longitudinal bore **324**. Channel **321**, designed to receive the tongue **318**, sits partially within the body segment **315**. That part of channel **321** sitting within the body segment **315** preferably conforms to the lip **320** of tongue **318**, and is provided with somewhat in excess of 180 degrees of arc so as to retain the lip **320** therein. That part of channel **321** which conforms to the constriction **319**, in contrast, is characterized by walls **322** extending from the body segment **315**. Walls **322**, each having an inner surface **323** which tapers inwardly toward the body segment **315**, are preferably sufficiently spaced apart so as to firmly engage the constriction **319**. The design of the tongue **318** and its complementary channel **321** allows the tongue **318** to laterally slide into the channel **321** of an adjacent linkage member **311** in a direction that is substantially perpendicular to the longitudinal bore **324**.

It will be appreciated that although parallel to the longitudinal bore **324**, the first plane in which tongue **318** lies, and the second plane in which channel **321** lies are perpendicular relative to one another (FIGS. 18B and 19B). A pair of adjacent links **313** thus provides the ability to pivot about two axes **314** that are at 90 degrees (i.e. perpendicular) to

one another in a manner of a universal joint, and still permits the axial transfer of torque. Since the present invention allows for such an ability with any three consecutive linkage members 311, the flexible shaft portion 310 may, therefore, conform to a wide range of curvatures along the bore axis 312 while still able to transmit torque to the drive tip 330. Alternatively, the plane in which each of the tongue 318 and channel 321 lies may be disposed at less than 90 degrees relative to one another. When this is the case, more than three consecutive linkage members 311 may be needed to achieve the same range of motion available with perpendicularly disposed planes.

Central bore 324 in each linkage member 311 extends longitudinally from the male end 316 to the female end 317. When a plurality of linkage members 311 are joined in series, the bore 324 of one linkage member is configured to align with the bore 324 of an adjacent linkage member so as to form a continuous passageway along the flexible shaft portion 310, and through which a guide wire may be received. To ensure that the coupling between adjacent linkage members 311 may further be sufficiently secured, the present invention includes a ring 325, as shown in FIGS. 20A-B. Ring 325 may be assembled onto the flexible shaft portion 310 by first placing the ring 325 about the tongue 318 of a linkage member 311. Subsequently, the tongue 318 is slid laterally into the channel 321 of an adjacent linkage member 311 in a direction that is substantially perpendicular to the longitudinal bore 324. The ring 325 is next advanced onto the female end 317 of the adjacent linkage member 311, and in particular, about the walls 322. The ring, thereafter, is preferably attached to the linkage member 311 by laser welding. However, other conventional methods of attachment well known in the art may also be used, for example, adhesive bonding or conventional welding. By providing a ring 325 about the female end 317 of a linkage member 311, in the presence of a lateral force, the tongue 318 is precluded from laterally sliding from the channel 321.

The distal end of the flexible shaft portion 310, as may be seen in FIG. 16, is coupled to the cannulated drive tip 330 via a link 331. The cannulation in the drive tip 330 is preferably aligned with the passageway formed from the bores 324 in the linkage members 311 of the flexible shaft portion 310 so that a guide wire may be received there-through. The drive tip 330 has a head, as described above for the angled driver, shaped for engagement with the proximal end of a screw. In the preferred embodiment of the invention, link 331 comprises a male end (not shown) on a terminal linkage member 326 of the flexible shaft portion 310, and a female end (not shown) on the drive tip 330. The female end on the drive tip 330 has a design similar to the female end 317 of a linkage member 311. In an alternative embodiment, link 331 may substitute, at the terminal linkage member 326, a female end 317 for the male end, and on the drive tip 330, a male end for the previously provided female end, or any combination thereof appropriate for the coupling of the flexible shaft portion 310 to the drive tip 330.

The proximal end of the flexible shaft portion 310, with reference still being made to FIG. 16, is coupled to a distal portion 342 of handle 340. The handle 340, as previously indicated, is substantially similar in configuration to the above-described handles, including the provision for the optional locking screw 230 in FIG. 12. The handle 340 may also include a tunnel along the longitudinal axis 312 that is aligned with the passageway formed by the longitudinal bore 324 in each linkage member 311 of the flexible shaft portion 310. In this way, the guide wire extending up the drive tip 330 and through the flexible shaft portion 310 may

also extend out through the handle 340. In accordance with one embodiment of the present invention, the handle 340, as can be seen in FIG. 16, further comprises a stiff shaft portion 350 disposed between the distal portion 342 of handle 340 and the flexible shaft portion 310. The stiff shaft portion 350, capable of transmitting rotation from the handle 340 to the flexible shaft portion 310, is cannulated to permit a guide wire extending through the flexible shaft portion 310 to extend out through the handle 340.

The stiff shaft portion 350 is coupled to the flexible shaft portion 310 via a link 351. Link 351 preferably includes, on the stiff shaft portion 350, a male end 353 which is substantially similar to the male end 316 of a linkage member 311, and a female end (not shown) on an initial linkage member 327 of the flexible shaft portion 310 for receiving the male end 353. As with link 331, link 351 may substitute, at the initial linkage member 327, a male end for the female end, and on the stiff shaft portion 350, a female end for the previously provided male end 353, or any combination thereof appropriate for coupling the stiff shaft portion 350 to the flexible shaft portion 310.

It will be appreciated that in use the flexible shaft portion 310, the drive tip 330, and the stiff shaft portion 350 must contact not only surrounding tissues, but must also be able to transmit torque from the handle 340. Accordingly, it is preferable that these components be made from a biocompatible yet strong material, for example stainless steel or molded plastic. Moreover, to protect the surrounding tissues from the being damaged between adjacent linkage members 311, the flexible shaft portion 310 is provided with a flexible sheath 352 disposed about the entire series of linkage members 311 (see FIGS. 15-16). If it is desired, the flexible sheath 352 may also be made to extend over the entire stiff shaft portion 350.

The surgical screwdrivers described herein are useful for arthroscopic ligament reconstruction procedures of the knee and of other joints in the human body. The knee is an example of a moveable joint that sustains injury to connective tissue with relative frequency. Although the surgical screwdrivers are described herein as applicable to methods of anterior cruciate ligament reconstruction, the surgical screwdriver according to the present invention can also be used in reconstructing posterior ligaments of the knee. Other joints also rely on ligaments to maintain function. In all joints, ligaments play an important role in holding the different bones of the joints in alignment.

A method of least invasive, or arthroscopic, anterior cruciate ligament reconstruction according to the present invention is shown in FIG. 3. An incision of minimal size is made medial to the tibial tubercle and distal to the joint line to harvest a portion of the patellar tendon which will serve as a graft ligament. Subsequently, this incision can be utilized as the portal 142 for inserting surgical instruments to fix one end of the graft ligament in the femoral bone tunnel as described below, and may also be used for access to the region of the cruciate ligament attachment sites to help determine proper placement of the tibial and femoral bone tunnels, with the knee being visualized with an arthroscope.

Tibial bone tunnel 128 and femoral bone tunnel 130 are formed respectively in the tibia and femur. The femoral bone tunnel is formed by instruments inserted in a cephalad direction through the tibial bone tunnel. The femoral bone tunnel 130 is formed as an open-ended longitudinally straight, cylindrical tunnel extending from an opening 132 on the femoral condyle at the attachment site of the anterior cruciate ligament on the femur to an opening 134 on the

lateral femoral cortex with (in one embodiment of the method) soft tissue covering the lateral femoral cortex remaining intact. The central longitudinal axis of the femoral bone tunnel is therefore substantially offset from the portal 142.

A ligament 136, such as a prosthetic ligament or the graft ligament harvested as previously described, having bone blocks 138 or other suitable terminus at its ends, is inserted initially through the tibial bone tunnel 128 and into the femoral bone tunnel 130 via a puncture wound. (The puncture wound is in line with opening 134 on the lateral femoral cortex and forward proximally and laterally on the patient's thigh.) A rigid pushing rod may be used to help push the graft through the tibial tunnel and into the femoral tunnel. The ligament 136 is then positioned so as to extend across the knee joint with a bone block 138 or other terminus positioned in each of the bone tunnels 128 and 130. A guide wire is inserted through the portal 142 into the femoral tunnel alongside the ligament 136. The guide wire is used to guide a bone screw positioned on a driver to the bone block at the end of the graft ligament for the purposes of securing the ligament with the screw. The guide wire 72 is made from a material such as a nickel-titanium alloy wire and is typically on the order of 14 inches (36 cm) in length. It is inserted into the tibial bone tunnel 128 and through the femoral tunnel 130, with the guide wire 72 exiting the knee through the soft tissue adjacent the lateral femoral cortex. Alternatively, the guide wire 72 can be inserted through the opening 134 on the lateral femoral cortex via the puncture wound described previously. The guide wire 72 is disposed parallel with the bone block 138 and the wall 140 and, therefore, parallel with the central longitudinal axis of the femoral bone tunnel. If the guide wire is inserted first through the puncture wound, it is advanced until an end of the guide wire 72 is visible at the knee joint. The visible end of the guide wire is grasped and disposed externally of the knee, creating a substantial bend in the guide wire 72, as shown in FIG. 3, using an instrument which is inserted through an anteromedial or anterolateral portal. The bend in the guide wire is due to the fact that the portal 142 is substantially offset from, and not aligned with, the central longitudinal axis of the femoral bone tunnel 130. A bone screw 144 having a cannula 145, in the form of a central, coaxial, longitudinal passage therein, is mounted on the end of the guide wire 72 externally of the knee, the cannula having a diameter slightly larger than the diameter of the guide wire 72. The end of the guide wire 72 is frictionally secured in the cylindrical passage 62 of the drive tip 52. The bone screw 144 is moved along the guide wire and mounted on the drive tip 52 by drive recess 143. Since the drive recess is coaxial with the cannula, the drive shaft 14 protrudes from the back end of the bone screw 144 by about 5 mm.

With the knee at an angle of substantially 90°, the angled screwdriver 10 is inserted at the knee joint via the portal 142. The driver is guided into the femoral bone tunnel 130 through the opening 132 on the femoral condyle by simultaneously turning and pushing the driver with the drive tip 52 oriented upwardly. The orientation of the drive tip is indicated by the indicator 127 on the forward handle section facing the surgeon, as shown in FIG. 3A. The direction of insertion from the portal 142 to the femoral bone tunnel 130 is at a non-zero acute angle with respect to the central longitudinal axis of the femoral bone tunnel because the portal 142 is not aligned with the femoral bone tunnel axis. The angled screwdriver 10, as guided by the guide wire 172, is moved forward along the femoral bone tunnel 130, with the longitudinal axis of the drive shaft 14 disposed parallel

with the longitudinal axis of the femoral bone tunnel; and, concurrently, the guide wire 72 is pushed cephalad in the tunnel and through the puncture wound.

Once the tip of the bone screw 144 is disposed adjacent the bone block 138, the rearward handle section 86 of the angled screwdriver is manually rotated relative to the forward handle section 84, while the forward handle section is grasped and held fixed, to rotate the operating shaft 12 relative to the sleeve 18. Consequently, the drive shaft 14 (the driven end), driven by handle 22, drives the screw 144 in a direction that is at a non-zero acute angle with respect to the handle (i.e. the driving end) of the angled screwdriver. Accordingly, the bone screw 144 is driven in a forward direction in the femoral bone tunnel 130 laterally between the bone block 138 and the wall 140 and parallel to the bone block 138 and the wall 140. A thread on the screw engages the tunnel wall 140 and the bone block 138 along the length of the bone block to fixate the ligament 136. The bone screw is driven externally of the knee from a direction offset from the direction of bone screw insertion and with the knee at an angle of substantially 90° such that the hyperflexion is avoided. The bone screw 144 is driven an additional 5 mm into the femoral bone tunnel 130 due to the exposed portion of the drive shaft 14 at the back end of the screw, allowing a countersink below the opening 132.

The angled screwdriver 10 is then pulled away from the screw 144 for removal through portal 142, and the guide wire 72 can be removed with the driver 10 or pulled away from the driver 10 for removal via the puncture wound in the soft tissue adjacent the lateral femoral cortex. The bone block 138 in the tibial bone tunnel 128 is then fixated by inserting a bone screw in the tibial bone tunnel and driving the bone screw parallel to the bone block and a wall of the tibial bone tunnel.

It will be appreciated that portal 142 can be the same portal utilized for alignment determination in forming the tibial and femoral bone tunnels, and that a single portal can be used throughout the procedure to harvest the patellar tendon graft, to orient the tibial and femoral bone tunnels, to help orient the graft ligament, and to insert the bone screw in the femoral bone tunnel.

It will also be appreciated that the drive shaft 14 of the surgical screwdriver can be offset from the handle 22 by the bend 78 or a curve as well as other configurations and that the bend, curve or other configuration can be rigid or flexible. The angled surgical screwdriver 10 can be used with or without the guide wire 72.

A related embodiment of the method of arthroscopic, anterior cruciate ligament reconstruction is shown in FIG. 5. Instead of the femoral bone tunnel being formed as an open-ended tunnel, the femoral bone tunnel 130 is formed as a blind, or closed-ended tunnel extending from an opening 132 on the femoral condyle to an end wall 172 such that the femoral bone tunnel does not broach the lateral femoral cortex.

A graft or prosthetic ligament 136 having bone blocks 138 at its ends is inserted in the tibial bone tunnel 128 via the portal to extend across the knee joint with a bone block 138 disposed in each of the bone tunnels of the femur and the tibia.

A bone screw 144 is mounted on the angled screwdriver 150 externally of the knee. The drive tip 52 of the driver is engaged in the drive recess of the screw and the retaining mechanism 152 is received in the cannula of the screw. In this configuration, the drive shaft 14 protrudes beyond the back end of the screw 144 substantially 5 mm. The curve of

the distal cylindrical section 158 of the wire 154 provides frictional engagement in the cannula of the screw 144. The screw is positively held by the retaining mechanism 152 upon the angled driver 150 prior to screw insertion. This arrangement allows manipulation of the screw at the knee joint while avoiding disengagement of the screw from the driver and possible loss of the screw in the knee.

With the knee at an angle of substantially 90°, the angled driver 150 with the screw 144 held thereon by retaining mechanism 152 is inserted at the knee joint via an anteromedial or anterolateral portal, such as anteromedial portal 174. The driver and screw are guided into the femoral bone tunnel 130 through the opening 132 on the femoral condyle. The drive tip 52 remains pointed upwards as indicated by indicator 127 facing the surgeon. The direction of insertion from the portal 174 to the femoral bone tunnel 130 is at a non-zero acute angle with respect to the central longitudinal axis of the femoral bone tunnel. The angled driver 150 is advanced along the femoral bone tunnel 130 in a direction parallel with the bone block 138 and the wall 140, and therefore, parallel with the longitudinal axis of the femoral bone tunnel until the bone screw 144 is positioned laterally between the bone block 138 and a wall 140 of the femoral bone tunnel as shown in FIG. 5.

Once the tip of the bone screw 144 is disposed adjacent the bone block 138, the rearward handle section 86 of the angled driver 150 is rotated relative to the forward handle section 84 while the forward handle section 86 is held fixed, to drive the bone screw 144 into the femoral bone tunnel 130 as described in connection with FIG. 3, and to fixate the ligament 136. Again the longitudinal axis of the operating shaft 12 is angularly disposed with respect to the direction of insertion. The screw is inserted an additional 5 mm into the femoral bone tunnel 128 and driven parallel with the bone block 138 in the tibial bone tunnel.

As in the case of FIG. 3, portal 174 can be the same portal as utilized in orienting the tibial and femoral bone tunnels, and a single portal can be used to harvest the patellar tendon graft, to orient the tibial and femoral bone tunnels, and to fixate the ligament in the femoral bone tunnel.

A guide wire can be used with the angled driver 150 by being driven into the femur to guide the driver during screw insertion. Such a guide wire can be used with the retaining mechanism 152, or in place of the retaining mechanism 152, or as a retaining mechanism by lengthening the distal cylindrical section 158.

As an alternative to the angled driver described above, the invention also provides, in a further embodiment, a method of arthroscopic, anterior cruciate ligament reconstruction using the flexible cannulated screwdriver 210 as shown in FIG. 14. For the ease of discussion, reference is now made to only the flexible cannulated screwdriver 214 with the understanding that the steps disclosed hereinafter are equally applicable to the flexible cannulated screwdriver 300 shown in FIGS. 15-16. The femoral tunnel may be formed as an open-ended tunnel or as a blind, or closed ended tunnel. The femoral tunnel may be drilled through the tibial tunnel with the knee at approximately 50 degrees of flexion. The flexible cannulated screwdriver used along a guide wire may be substituted for the angled driver in above-described methods or the following method may be employed advantageously. A graft or prosthetic ligament 136 having bone blocks 138 at its end is inserted in the tibial bone tunnel 128. A pushing rod may be used to push the graft across the knee joint into the femoral tunnel so that one bone block 138 is disposed in each of the bone tunnels of the femur and the tibia. The knee

is placed at 90 degrees of flexion for insertion of the screw. With the knee in this position, the ligament advantageously drops back away from the path of the interference screw. A guide wire 72 is inserted through the anteromedial portal 142 into the femoral tunnel alongside the bone block 138 therein. If desired, the curved sheath 220 may be slid over the guide wire to protect surrounding tissue from the screw threads before the screw is driven into engagement with the bone block and bone tunnel. However, with the knee placed at about 90° the sheath is generally not required. A cannulated interference screw 144 is mounted onto the guide wire 72. The flexible cannulated screwdriver is then mounted on the guide wire such that the drive tip 246 of the screwdriver engages the screw. The driver and screw are guided into the knee joint along the guide wire through the anteromedial portal. The driver and screw continue along the wire through the femoral condyle into the femoral bone tunnel. The shaft of the driver advantageously bends along the guide wire from the anteromedial portal into the bone tunnel. The screw is driven between the bone block and the wall parallel with the longitudinal axis of the femoral bone tunnel. Rotation of the driver handle is transmitted by the shaft to the screw. Once the screw is satisfactorily secured, the driver is pulled out back along the guide wire. If desired, the locking screw on the driver handle can be tightened upon the guide wire so that the guide wire is removed along with the driver.

A related embodiment of an angled driver according to the present invention is shown at the distal end in FIGS. 6 and 7 as item 180, which is similar to the angled driver 150, and includes a drive head housing 20 mounting the drive shaft and a distal end of the operating shaft, the drive shaft including a drive tip 52 having a hexagonal configuration in cross-section for engaging a hexagonal drive recess 143 of an interference bone fixation screw 144.

Drive head housing 20 of angled driver 180 is formed integrally with sleeve 18 and includes a flared section 182 distally joined to the sleeve 18, an intermediate cylindrical section 184 joined to flared section 182 and an angled section 186 joined to intermediate section 184. The flared and intermediate sections 182 and 184 are axially aligned, while the angled section 186 is angularly offset from the flared and intermediate sections such that a longitudinal axis of the angled section is disposed at an angle, with respect to a longitudinal axis of the flared and intermediate sections, that is substantially the same as the angle that the longitudinal axis of the drive shaft is disposed with the longitudinal axis of the operating shaft.

The drive tip 52 of the angled driver 180 is formed of six facets for engaging the drive recess 143 of the bone screw 144. Drive tip 52 can have a configuration in cross-section that is substantially constant along the length of the drive tip as shown in FIG. 6, or the drive tip 52 can be tapered or stepped in a distal direction to further facilitate insertion through very small portals and mobility at the knee joint. It includes a cylindrical passage 62 coaxial with the drive shaft as shown in FIG. 7, for securing retaining mechanism 152. Retaining mechanism 152 includes a wire 154 press fit into passage 62 and having a distal cylindrical section 158 protruding beyond the drive tip 52. The distal cylindrical section 158 is formed with a thermally set, angled bend along a longitudinal axis of the wire 154, the bend being offset from the longitudinal axis of the drive shaft for being disposed in the cannula 145 of the bone screw 144. The bone screw is mounted on drive tip 52 such that the screw will be forced slightly out of axial alignment with the drive tip 52 to produce frictional engagement of the drive tip in the drive recess of the screw to resist disengagement of the screw from the angled driver prior to screw insertion as shown in FIG. 6.

A further modification of an angled driver according to the present invention is shown in FIG. 8 at 190, in which the bone screw is mounted on drive tip 52 without forcing the screw out of axial alignment with the drive tip. In all other respects, angled driver 190 is substantially the same as angled driver 180.

Both angled drivers 180 and 190 and the flexible cannulated screwdriver can be utilized for insertion of bone screws, in arthroscopic cruciate ligament reconstruction in bone tunnels from directions offset from the direction of screw insertion and from portals not aligned with the bone tunnels as previously described; and, the angled screwdriver 180 can be used with or without a guide wire.

The screwdrivers described herein allow bone screws to be inserted in bone tunnels parallel with walls of the bone tunnels and bone blocks in the bone tunnels to obtain maximum thread purchase along the entire length of the bone blocks with the screws being driven from directions offset from the direction of screw insertion. Bone screws can be inserted in femoral bone tunnels directly from anteromedial or anterolateral portals and without accessing the femoral bone tunnels through the tibial bone tunnels. For example, bone screws can be inserted in the femoral bone tunnels with the knee positioned at an angle of substantially 90°. The present invention removes the undesirable requirement for hyperflexion of the knee in order to insert bone screws.

In addition, the same portal can be employed to perform procedures preparatory to graft fixation, to orient the tibial and femoral bone tunnels and to insert interference screws in the femoral bone tunnel, thereby eliminating the need for portals in soft tissue adjacent the lateral femoral cortex specifically formed for the purpose of inserting bone screws in the femoral bone tunnel. Using the methods of this invention, trauma and invasiveness are minimized.

The surgical screwdriver and its methods of use described above for anterior cruciate ligament reconstruction of the knee can also be applied to other ligament reconstruction procedures including arthroscopic posterior cruciate ligament reconstruction of the knee. In the latter case, the driver provides a means to insert bone screws in bone tunnels in a direction parallel with walls of the bone tunnels and bone blocks in the bone tunnels to fixate a graft or prosthetic ligament in the anatomic position of the posterior cruciate ligament while introducing the screws through portals not aligned with the direction of screw insertion. The flexible cannulated screwdriver advantageously accommodates a wide range of angles between the portal and the tunnel.

Further details concerning practice of the present invention are described by David A. McGuire, M.D., an inventor herein, in the brochure entitled "The Paramax ACL Guide System Surgical Technique", and incorporated herein by reference (published by Linvatec Corporation, Largo, Fla. 34643) submitted herewith.

Inasmuch as the present invention is subject to many variations, modifications and changes in detail, it is intended that the subject matter discussed above and shown in the accompanying drawings may be interpreted as illustrative not in a limiting sense.

What is claimed is:

1. A screwdriver comprising:

(a) a rotatable handle having a distal portion, and a central longitudinal axis;

(b) a flexible shaft portion coupled to the distal portion of the handle, the flexible shaft portion having a plurality of linkage members disposed in series, each linkage member having a bore extending longitudinally there-through;

(c) a plurality of links, each link joining a linkage member to an adjacent linkage member by a means for preventing adjacent linkage members from substantially rotating about the longitudinal axis relative to one another, so as to permit torque to be transmitted along the linkage members while permitting adjacent linkage members to be pivotally movable with respect to one another about a pivot axis that is transverse to the longitudinal axis; and

(d) a cannulated drive tip attached to a terminal linkage member of the flexible shaft portion for driving a cannulated screw with rotation transmitted from the flexible shaft portion.

2. A screwdriver as set forth in claim 1, wherein the flexible shaft portion and the cannulated driving tip are aligned such that a guide wire may be inserted into the cannulated drive tip and through the longitudinal bore of each linkage member in the flexible shaft portion.

3. A screwdriver as set forth in claim 1, wherein each linkage member includes a male end and a female end, the female end being adapted to engage a male end of an adjacent linkage member.

4. A screwdriver as set forth in claim 3 wherein the male end includes a tongue lying generally in a first plane parallel to the longitudinal bore, and the female end includes a channel adapted to receive the tongue of an adjacent linkage member, the channel defining a second plane parallel to the longitudinal bore, wherein the first and second planes are less than perpendicular to one another.

5. A screwdriver as set forth in claim 3, wherein the distal portion of the handle terminates in one of a male end and a female end for engaging the other of a male end and a female end of a linkage member.

6. A screwdriver as set forth in claim 5, wherein the flexible shaft portion terminates in one of a male end and a female end for engaging the other of a male end and a female end of the drive tip.

7. A screwdriver as set forth in claim 3, wherein the linkage member is generally cylindrical in shape.

8. A screwdriver as set forth in claim 3, further including a flexible sheath disposed about the entire series of linkage members of the flexible shaft portion.

9. A screwdriver as set forth in claim 1, further comprising a stiff shaft portion disposed between the distal portion of the handle and the flexible shaft portion and having a passageway therethrough, the passageway being in axial alignment with the central longitudinal axis.

10. A screwdriver comprising:

(a) a rotatable handle having a distal portion, and a central longitudinal axis;

(b) a flexible shaft portion coupled to the distal portion of the handle, the flexible shaft portion having a plurality of linkage members disposed in series, each linkage member having a bore extending longitudinally there-through and being joined to an adjacent linkage member via link, so as to permit adjacent linkage members to be pivotally movable with respect to one another about a pivot axis that is transverse to the longitudinal axis, so that the flexible shaft portion may transmit rotation from the handle while conforming generally to a curvature along the longitudinal axis; and

(c) a cannulated drive tip attached to terminal linkage member of the flexible shaft portion for driving a cannulated screw with rotation transmitted from the flexible shaft portion;

wherein each linkage member includes a male end and a female end, the female end being adapted to engage a male end of an adjacent linkage member, and

wherein the male end includes a tongue lying generally in a first plane parallel to the longitudinal bore, and the female end includes a channel adapted to receive the tongue of an adjacent linkage member, the channel defining a second plane parallel to the longitudinal bore, wherein the first and second planes are perpendicular to one another.

11. A screwdriver comprising:

- (a) a rotatable handle having a distal portion, and a central longitudinal axis;
- (b) a flexible shaft portion coupled to the distal portion of the handle, the flexible shaft portion having a plurality of linkage members disposed in series, each linkage member having a bore extending longitudinally therethrough and being joined to an adjacent linkage member via link, so as to permit adjacent linkage members to be pivotally movable with respect to one another about a pivot axis that is transverse to the longitudinal axis, so that the flexible shaft portion may transmit rotation from the handle while conforming generally to a curvature along the longitudinal axis; and
- (c) a cannulated drive tip attached to terminal linkage member of the flexible shaft portion for driving a cannulated screw with rotation transmitted from the flexible shaft portion;
 - wherein each linkage member, being generally cylindrical in shape, includes a male end and a female end, the female end being adapted to engage a male end of an adjacent linkage member, and
 - wherein each linkage member further includes a ring positioned circumferentially about the female end thereof for securing the engagement between the female end and the male end of an adjacent linkage member.

12. A screwdriver comprising:

- (a) a rotatable handle having a distal portion, and a central longitudinal axis;
- (b) a flexible shaft portion coupled to the distal portion of the handle, the flexible shaft portion having a plurality of linkage members disposed in series, each linkage member having a bore extending longitudinally therethrough and being joined to an adjacent linkage member via link, so as to permit adjacent linkage members to be pivotally movable with respect to one another about a pivot axis that is transverse to the longitudinal axis, so that the flexible shaft portion may transmit rotation from the handle while conforming generally to a curvature along the longitudinal axis; and
- (c) a cannulated drive tip attached to terminal linkage member of the flexible shaft portion for driving a cannulated screw with rotation transmitted from the flexible shaft portion
 - wherein the handle includes a tunnel along the longitudinal axis so that the entire screwdriver possesses an axially disposed cannula.

13. A surgical screwdriver for rotationally advancing a screw into a bone, the screwdriver comprising:

- (a) a rotatable rigid shaft portion having a distal end, a proximal end, and a passageway extending from the distal end to the proximal end along a longitudinal axis;
- (b) a flexible shaft portion coupled to the distal end of the rotatable rigid shaft portion, the flexible shaft portion having a plurality of linkage members disposed in series, each linkage member having a bore extending longitudinally therethrough;
- (c) a plurality of links, each link joining a linkage member to an adjacent linkage member by a means for prevent-

ing adjacent linkage members from substantially rotating about the longitudinal axis relative to one another, so as to permit torque to be transmitted along the linkage members while permitting adjacent linkage members to be pivotally movable with respect to one another about a pivot axis that is transverse to the longitudinal axis;

- (d) a handle fixed to the proximal end of the rigid shaft portion for rotating the stiff shaft portion; and
- (e) a cannulated drive tip attached to a terminal linkage member of the flexible shaft portion for advancing, upon rotation of the handle, a cannulated screw situated on a guide wire.

14. A surgical screwdriver as set forth in claim 13, wherein the cannulated drive tip is elongated so that when the tip engages the cannulated screw at its proximal end, a portion of the tip protrudes beyond the proximal end of the screw by a distance so as to allow the screw to be driven into the bone until its proximal end lies beneath the bone surface by such a distance.

15. A surgical screwdriver as set forth in claim 14, wherein such distance is approximately 5 mm.

16. A surgical screwdriver as set forth in claim 13, wherein each linkage member includes a male end and a female end, the female end being adapted for engaging a male end of an adjacent linkage member.

17. A surgical screwdriver as set forth in claim 16, wherein the male end includes a tongue lying generally in a first plane parallel to the longitudinal bore, and the female end includes a channel adapted to receive the tongue of an adjacent member, the channel defining a second plane parallel to the longitudinal bore, wherein the first and second planes are less than perpendicular to one another.

18. A surgical screwdriver as set forth in claim 16, wherein the proximal end of the rigid shaft handle terminates in one of a male end and a female end for engaging the other of a male end and a female end of a linkage member.

19. A surgical screwdriver as set forth in claim 18, wherein the flexible shaft portion terminates in one of a male end and a female end for engaging the other of a male end and a female end of the drive tip.

20. A surgical screwdriver as set forth in claim 16 wherein the linkage member is generally cylindrical in shape.

21. A surgical screwdriver as set forth in claim 16 further including a flexible sheath disposed about the entire series of linkage members of the flexible shaft portion.

22. A surgical screwdriver as set forth in claim 21, wherein the flexible sheath is also disposed about the rigid shaft portion.

23. A surgical screwdriver for rotationally advancing a screw into a bone, the screwdriver comprising:

- (a) a rotatable rigid shaft portion having a distal end, a proximal end, and a passageway extending from the distal end to the proximal end along a longitudinal axis;
- (b) a flexible shaft portion coupled to the distal end of the stiff shaft portion for being rotated upon rotation of the stiff shaft portion, the flexible shaft portion having a plurality of linkage members disposed in series, each linkage member having a bore extending longitudinally therethrough and being joined to an adjacent linkage member via a link so as to permit adjacent linkage members to be pivotally movable with respect to one another about a pivot axis that is transverse to the longitudinal axis;
- (c) a handle fixed to the proximal end of the rigid shaft portion for rotating the stiff shaft portion; and

(d) a cannulated drive tip attached to a terminal linkage member of the flexible shaft portion for advancing, upon rotation of the handle, a cannulated screw situated on a guide wire;

wherein the handle is cannulated and the passageway aligned so that the guide wire may extend up through the drive tip, through the flexible and rigid shaft portions, and out through the handle.

24. A surgical screwdriver for rotationally advancing a screw into a bone, the screwdriver comprising:

(a) a rotatable rigid shaft portion having a distal end, a proximal end, and a passageway extending from the distal end to the proximal end along a longitudinal axis;

(b) a flexible shaft portion coupled to the distal end of the stiff shaft portion for being rotated upon rotation of the stiff shaft portion, the flexible shaft portion having a plurality of linkage members disposed in series, each linkage member having a bore extending longitudinally therethrough and being joined to an adjacent linkage member via a link so as to permit adjacent linkage members to be pivotally movable with respect to one another about a pivot axis that is transverse to the longitudinal axis;

(c) a handle fixed to the proximal end of the rigid shaft portion for rotating the stiff shaft portion; and

(d) a cannulated drive tip attached to a terminal linkage member of the flexible shaft portion for advancing, upon rotation of the handle, a cannulated screw situated on a guide wire;

wherein each linkage member includes a male end and a female end, the female end being adapted for engaging a male end of an adjacent linkage member, and

wherein the male end includes a tongue lying generally in a first plane parallel to the longitudinal bore, and the female end includes a channel adapted to receive the tongue of an adjacent linkage member, the channel defining a second plane parallel to the longitudinal bore, wherein the first and second planes are perpendicular to one another.

25. A surgical screwdriver for rotationally advancing a screw into a bone, the screwdriver comprising:

(a) a rotatable rigid shaft portion having a distal end, a proximal end, and a passageway extending from the distal end to the proximal end along a longitudinal axis;

(b) a flexible shaft portion coupled to the distal end of the rotatable rigid shaft portion, the flexible shaft portion having a plurality of linkage members disposed in series, each linkage member having a bore extending longitudinally therethrough;

(c) a plurality of links, each link joining a linkage member to an adjacent linkage member to permit torque to be transmitted along the linkage members while permitting adjacent linkage members to be pivotally movable with respect to one another about a pivot axis that is transverse to the longitudinal axis;

(d) a handle fixed to the proximal end of the rigid shaft portion for rotating the stiff shaft portion; and

(e) a cannulated drive tip attached to a terminal linkage member of the flexible shaft portion for advancing, upon rotation of the handle, a cannulated screw situated on a guide wire;

wherein each linkage member, being generally cylindrical in shape, includes a male end and a female end, the female end being adapted to engage a male end of an adjacent linkage member; and

wherein each linkage member further includes a ring positioned circumferentially about the female end thereof for securing the engagement between the female end and the male end of the adjacent linkage members.

26. A surgical screwdriver for rotationally advancing a screw into a bone, the screwdriver comprising:

(a) a rotatable rigid shaft having a distal end, a proximal end, and a passageway extending from the distal end to the proximal end along a longitudinal axis;

(b) a flexible shaft portion coupled to the distal end of the stiff shaft portion for being rotated upon rotation of the stiff shaft portion, the flexible shaft portion having a plurality of linkage members disposed in series, each linkage member having a bore extending longitudinally therethrough and being joined to an adjacent linkage member via a link so as to permit adjacent linkage members to be pivotally movable with respect to one another about a pivot axis that is transverse to the longitudinal axis;

(c) a handle fixed to the proximal end of the rigid shaft portion for rotating the stiff shaft portion; and

(d) a cannulated drive tip attached to a terminal linkage member of the flexible shaft portion for advancing, upon rotation of the handle, a cannulated screw situated on a guide wire;

wherein the handle includes a longitudinal tunnel so that the screwdriver possesses an axially disposed cannula.

27. A screwdriver comprising:

(a) a rotatable handle having a distal portion, and a central longitudinal axis;

(b) a flexible shaft portion coupled to the distal portion of the handle, the flexible shaft portion having a plurality of linkage members disposed in series, each linkage member having a bore extending longitudinally therethrough;

(c) a plurality of links, each link joining a linkage member to an adjacent linkage member, so as to permit torque to be transmitted along the linkage members while permitting adjacent linkage members to be pivotally movable with respect to one another about a pivot axis that is transverse to the longitudinal axis to conform generally to a curvature along the longitudinal axis; and

(d) a cannulated drive tip attached to a terminal linkage member of the flexible shaft portion for driving a cannulated screw with rotation transmitted from the flexible shaft portion;

wherein each linkage member includes a male end and a female end, the female end being adapted to engage a male end of an adjacent linkage member, and

wherein the male end includes a tongue lying generally in a first plane parallel to the longitudinal bore, and the female end includes a channel adapted to receive the tongue of an adjacent linkage member, the channel defining a second plane parallel to the longitudinal bore, wherein the first and second planes are perpendicular to one another.

28. A screwdriver comprising:

(a) a rotatable handle having a distal portion, and a central longitudinal axis;

(b) a flexible shaft portion coupled to the distal portion of the handle, the flexible shaft portion having a plurality of linkage members disposed in series, each linkage member having a bore extending longitudinally therethrough;

25

- (c) a plurality of links, each link joining a linkage member to an adjacent linkage member, so as to permit torque to be transmitted along the linkage members while permitting adjacent linkage members to be pivotally movable with respect to one another about a pivot axis that is transverse to the longitudinal axis to conform generally to a curvature along the longitudinal axis; and
- (d) a cannulated drive tip attached to a terminal linkage member of the flexible shaft portion for driving a cannulated screw with rotation transmitted from the flexible shaft portion;
- wherein each linkage member, being generally cylindrical in shape, includes a male end and a female end, the female end being adapted to engage a male end of an adjacent linkage member, and
- wherein each linkage member further includes a ring positioned circumferentially about the female end thereof for securing the engagement between the female end and the male end of an adjacent linkage member.

29. A screwdriver comprising:

- (a) a rotatable handle having a distal portion, and a central longitudinal axis;
- (b) a flexible shaft portion coupled to the distal portion of the handle, the flexible shaft portion having a plurality of linkage members disposed in series, each linkage member having a bore extending longitudinally therethrough;
- (c) a plurality of links, each link joining a linkage member to an adjacent linkage member, so as to permit torque to be transmitted along the linkage members while permitting adjacent linkage members to be pivotally movable with respect to one another about a pivot axis that is transverse to the longitudinal axis to conform generally to a curvature along the longitudinal axis; and
- (d) a cannulated drive tip attached to a terminal linkage member of the flexible shaft portion for driving a cannulated screw with rotation transmitted from the flexible shaft portion;
- wherein the handle includes a tunnel along the longitudinal axis so that the entire screwdriver possesses an axially disposed cannula.

30. A surgical screwdriver for rotationally advancing a screw into a bone, the screwdriver comprising:

- (a) a rotatable rigid shaft portion having a distal end, a proximal end, and a passageway extending from the distal end to the proximal end along a longitudinal axis;
- (b) a flexible shaft portion coupled to the distal end of the rotatable rigid shaft portion, the flexible shaft portion having a plurality of linkage members disposed in series, each linkage member having a bore extending longitudinally therethrough;
- (c) a plurality of links, each link joining a linkage member to an adjacent linkage member to permit torque to be transmitted along the linkage members while permitting adjacent linkage members to be pivotally movable with respect to one another about a pivot axis that is transverse to the longitudinal axis;
- (d) a handle fixed to the proximal end of the rigid shaft portion for rotating the stiff shaft portion; and
- (e) a cannulated drive tip attached to a terminal linkage member of the flexible shaft portion for advancing, upon rotation of the handle, a cannulated screw situated on a guide wire;
- wherein the handle is cannulated and the passageway aligned so that the guide wire may extend up through

26

the drive tip, through the flexible and rigid shaft portions, and out through the handle.

31. A surgical screwdriver for rotationally advancing a screw into a bone, the screwdriver comprising:

- (a) a rotatable rigid shaft portion having a distal end, a proximal end, and a passageway extending from the distal end to the proximal end along a longitudinal axis; a flexible shaft portion coupled to the distal end of the rotatable rigid shaft portion, the flexible shaft portion having a plurality of linkage members disposed in series, each linkage member having a bore extending longitudinally therethrough;
- (c) a plurality of links, each link joining a linkage member to an adjacent linkage member to permit torque to be transmitted along the linkage members while permitting adjacent linkage members to be pivotally movable with respect to one another about a pivot axis that is transverse to the longitudinal axis;
- (d) a handle fixed to the proximal end of the rigid shaft portion for rotating the stiff shaft portion; and
- (e) a cannulated drive tip attached to a terminal linkage member of the flexible shaft portion for advancing, upon rotation of the handle, a cannulated screw situated on a guide wire;
- wherein each linkage member includes a male end and a female end, the female end being adapted for engaging a male end of an adjacent linkage member, and
- wherein the male end includes a tongue lying generally in a first plane parallel to the longitudinal bore, and the female end includes a channel adapted to receive the tongue of an adjacent linkage member, the channel defining a second plane parallel to the longitudinal bore, wherein the first and second planes are perpendicular to one another.

32. A surgical screwdriver for rotationally advancing a screw into a bone, the screwdriver comprising:

- (a) a rotatable rigid shaft portion having a distal end, a proximal end, and a passageway extending from the distal end to the proximal end along a longitudinal axis;
- (b) a flexible shaft portion coupled to the distal end of the rotatable rigid shaft portion, the flexible shaft portion having a plurality of linkage members disposed in series, each linkage member having a bore extending longitudinally therethrough;
- (c) a plurality of links, each link joining a linkage member to an adjacent linkage member to permit torque to be transmitted along the linkage members while permitting adjacent linkage members to be pivotally movable with respect to one another about a pivot axis that is transverse to the longitudinal axis;
- (d) a handle fixed to the proximal end of the rigid shaft portion for rotating the stiff shaft portion; and
- (e) a cannulated drive tip attached to a terminal linkage member of the flexible shaft portion for advancing, upon rotation of the handle, a cannulated screw situated on a guide wire;
- wherein each linkage member, being generally cylindrical in shape, includes a male end and a female end, the female end being adapted to engage a male end of an adjacent linkage member; and
- wherein each linkage member further includes a ring positioned circumferentially about the female end thereof for securing the engagement between the female end and the male end of the adjacent linkage members.

27

33. A surgical screwdriver for rotationally advancing a screw into a bone, the screwdriver comprising:

- (a) a rotatable handle having a distal portion, and a central longitudinal axis;
- (b) a flexible shaft portion coupled to the distal portion of the handle, the flexible shaft portion having a plurality of linkage members disposed in series, each linkage member having a bore extending longitudinally there-through;
- (c) a plurality of links, each link joining a linkage member to an adjacent linkage member, so as to permit torque to be transmitted along the linkage members while permitting adjacent linkage members to be pivotally

28

movable with respect to one another about a pivot axis that is transverse to the longitudinal axis to conform generally to a curvature along the longitudinal axis; and

- (d) a cannulated drive tip attached to a terminal linkage member of the flexible shaft portion for driving a cannulated screw with rotation transmitted from the flexible shaft portion;

wherein the handle includes a longitudinal tunnel so that the screwdriver possesses an axially disposed cannula.

* * * * *